

2230 Level Lift Field Cultivator QUICK REFERENCE GUIDE

NOTE: Use this as a reference guide. For further details, please see the Operator's Manual provided with the machine.

Preparing Machine — Adjust Front-to-Rear Level

CAUTION: Do not unscrew the turnbuckle (A) to expose more than 51 mm (2 in) of the threads on either eyebolt. Eyebolts can pull out of tube end, resulting in machine dropping unexpectedly, and causing injury or death to you or others.

IMPORTANT: Check tires for correct inflation before leveling machine. Perform procedure on a level surface.

NOTE: Machine can need adjusting when moving from field to field or when using a tractor with different drawbar height. Adjustment wrench is provided with machine.

- PRELIMINARY LEVELING: Unfold wings to field position.
- Lower mainframe so sweeps are 51 mm (2 in) above level surface.
- Measure ground clearance at the rear corners of the main frame.
- Remove wrench from turnbuckle (A). Lift turnbuckle retainer (C) and turn turnbuckle using wrench until frame ground clearance is slightly higher than 6.4—12.7 mm (1/4—1/2 in) in front. This compensates for natural draft forces during operation.
- FINAL LEVELING: Observe machine from side as it travels past in field. Adjust turn buckle to provide level fore/aft main frame.
- Make sure grease fitting (B) points either up or down, not sideways, when adjustment is finished.
- Lower Retainer and lock wrench on turnbuckle using pin and cotter pin.

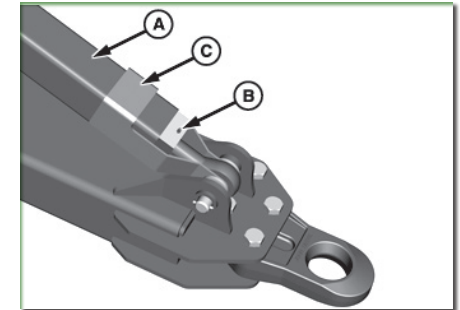

IMPORTANT: For best results perform final leveling in the field under normal operating conditions, at desired depth, and normal speed.

Preparing Machine — Adjust Side-to-Side Level

IMPORTANT: Check tires for correct inflation before leveling machine. Perform procedure on a level surface. 5-SECTION MACHINES—Inner wings MUST be leveled BEFORE outer wings. Re-phase depth control cylinders before leveling.

NOTE: Initial machine leveling should be done on a flat, level concrete surface. Final machine leveling should be done in field at ground level. Level adjustment can be different for both wings, due to variations in manufacturing. Adjustment wrench is provided with machine.

- Unfold wings to field position.
- Lower frame so sweeps are 51 mm (2 in) above a level surface. Check that center frame is level.
- Measure ground clearance at the wing rear bar.
- Loosen lock nut (A) and turn adjusting nut (B) until wing ground clearance is equal to the main frame and all sweeps are same distance from surface. Tighten lock nut.
- Perform adjustment procedure on opposite wing
- 5-SECTION MACHINES: Perform adjustment procedure for outer wings.

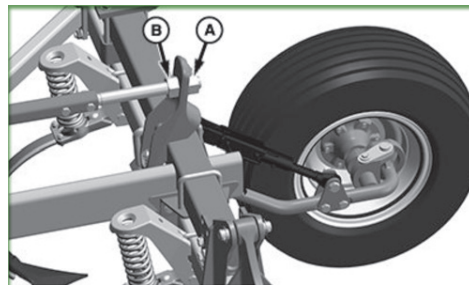
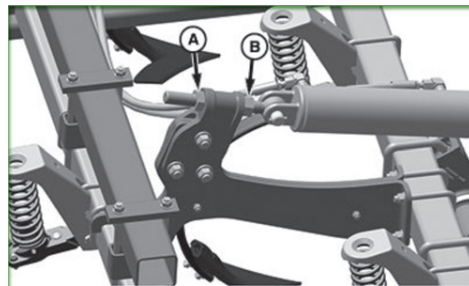

Set Rolling Basket Down-Pressure

IMPORTANT: Basket pressure can be adjusted 0—900 psi. See pressure gauge (A). Do not use more down-pressure than necessary or excessive wear and damage to machine could result. Too much down pressure can lift rear of machine, causing it to become un-level and result in undesired field finish.

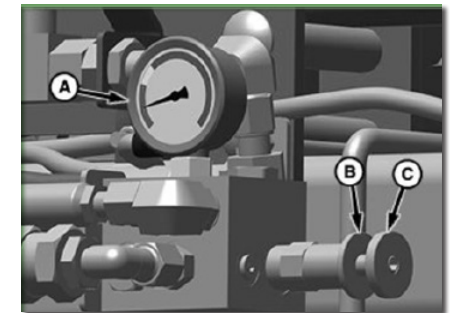

- Adjust down-pressure to initial setting by rotating knob (B).
- Once set, lock knob in position with collar (C).
- Make a trial pass in field. If rolling basket operation is not satisfactory, adjust hydraulic pressure as needed.
- Down-pressure applied - Adjust pressure applied using the manual adjustment and gauge at machine front. Apply only enough pressure to chop and size material to desired finish.
- Float - Allows light fluffing and moderate leveling of the soil profile, and may help reduce plugging when operating across moderately wet soil conditions.
- Fully raised - Allows continued operation in harsh, muddy soil conditions, or if a more pronounced mounding pattern is desired.

2230 Level Lift Field Cultivator QUICK REFERENCE GUIDE

Adjust Coil Tine Spring Tension

There are 3 different settings for coil tine spring tension:

- Remove pin (C), adjust spring tension to desired position, and reinstall pin.
- Light Tension Position (A) is least aggressive.
- Medium Tension Position (B) is medium aggressive.
- High Tension Position Shown With Pin (C) is most aggressive.
- Repeat for other drawbar locations.

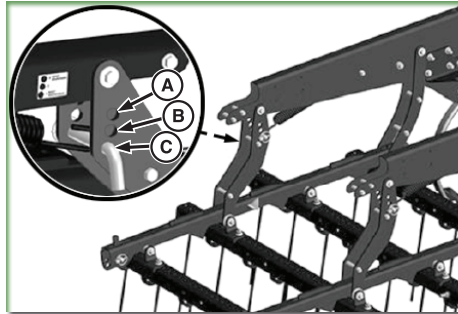

Adjust Coil Tine Angle

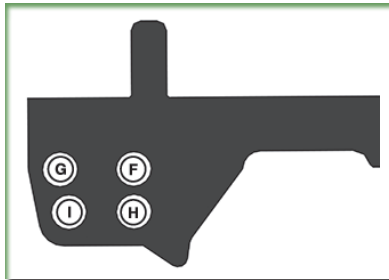
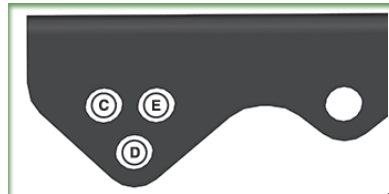
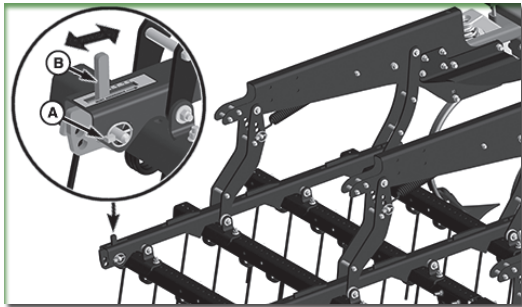

IMPORTANT: Make harrow tine angle adjustments with the machine raised.

1. Remove pin (A), slide lever (B) to desired position, and reinstall pin.
2. Repeat for other drawbar locations.

NOTE: Use less aggressive settings for better residue flow. See table for adjusting the harrow angle. Coil tine angle is most aggressive in position 1 and least aggressive in position 5.

| Coil Tine Angle | Attachment Plate Hole Position | Lift Bar Hole Position |
|-----------------|--------------------------------|------------------------|
| 1 | D | I |
| 2 | C | G |
| 3 | E | F |
| 4 | D | H |
| 5 | C | F |

Adjust Harrow Spike Angle

IMPORTANT: Adjusting the spike angle controls harrow aggressiveness and residue flow capability. Spike angle should be adjusted per field conditions for the best combined performance of residue flow and field leveling.

NOTE: Use less aggressive settings for better residue flow.

1. Adjust spike angle by raising the machine and moving the pin to the desired position: (A) is least aggressive, (B) medium aggressive, and (C) most aggressive.
2. Repeat for other drawbar locations.

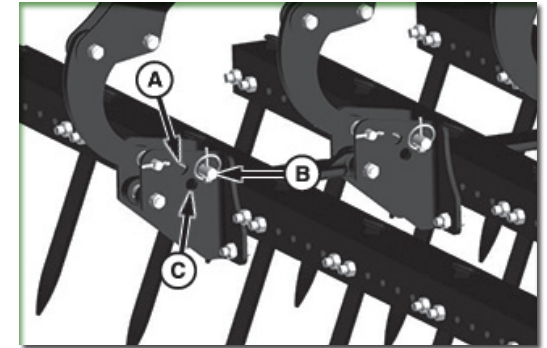

Adjust Harrow Height and Draft

IMPORTANT: Before adjusting any harrow, be sure the fore/aft and side-to-side adjustments on machine have been completed. When making harrow adjustments only change one adjustment at a time. Run machine at desired working depth and speed between adjustments to verify performance. Spike Harrows With Rolling Baskets—Draft chains must be adjusted so spike harrow does NOT contact rolling basket.

NOTE: Harrow height is preset.

- Once desired working depth is set, spikes are 51—101 mm (2—4 in) (A) lower than sweeps when swept to working spike angle position.
- Set chain (B) for the desired harrow draft and adjust so that hang chains or linkages (C) are not under load at operating depth and speed.
- Repeat for other drawbar locations.

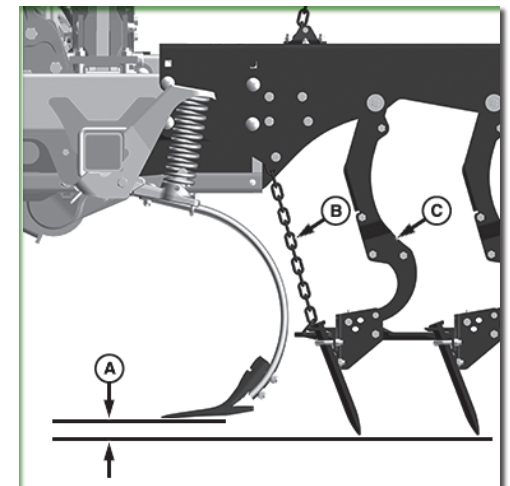

TruSet™ - 2230 Level Lift Field Cultivator QUICK REFERENCE GUIDE

Settings

Press Settings Softkey.

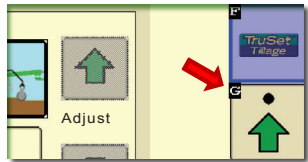

Tool and SCV Settings

Verify that machine is set up properly and SCV functions are assigned correctly.

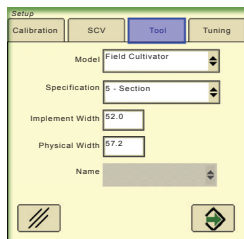
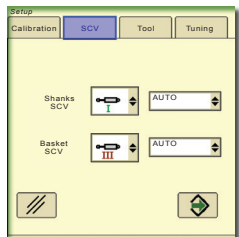

Adjust TruSet™ Tuning

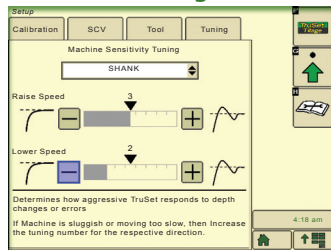

- Raise and lower speed are independently adjustable.
- Using a higher number causes the machine to respond more quickly.
- Using a lower number causes the machine to respond more slowly.

Operation Setup

Press Operational Settings Softkey

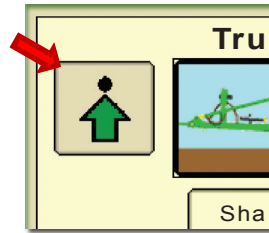

Previous Page – Softkey

Increment Step Size – Softkey

Cylinder Re-phase – Softkey

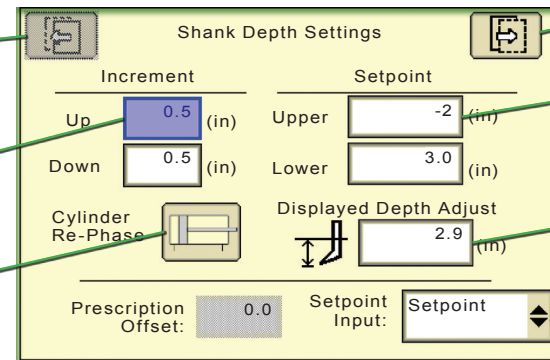

Next Page – Softkey

Upper setpoint on shank limits raise height on headlands (Up-detent).

Field Calibration: Adjust the “actual depth” to zero the machine.

Input type: Setpoint or Prescription.

General Operation

- Detenting ripper SCV lever downward will put all sections into AUTO mode.
- Rolling basket down pressure is enabled using the power button.
- Tractor must be moving >1 mph to activate TruSet™.
- Verify that hoses are connected correctly. Pressure and return hoses cannot be reversed.

Using Presets

- Adjust the setpoint fields to desired values.
- Press Save softkey.
- Press desired Preset softkey.
- Accept changes.

NOTE: Presets can be named.

Operational Settings – Access a Setup Page for each of the operations.

Incremental Adjustment – Select an operation to make incremental adjustments using the arrow softkeys.

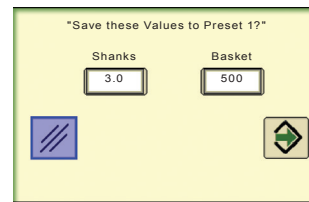

Preset and Save – Softkey

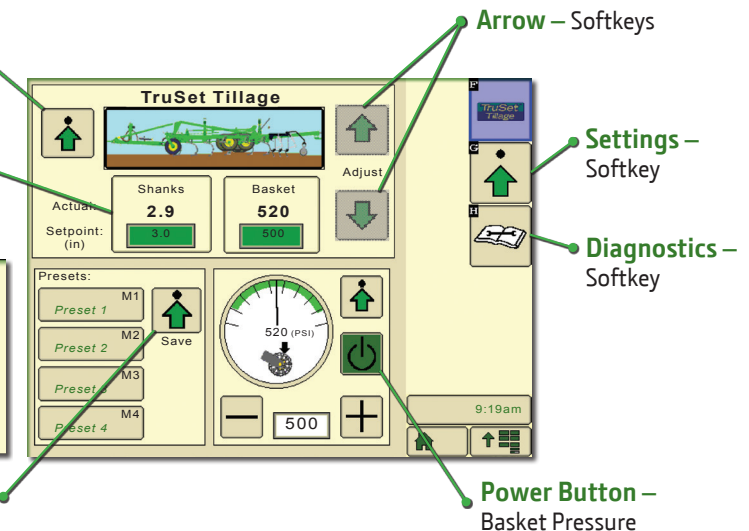

Arrow – Softkeys

Settings – Softkey

Diagnostics – Softkey

Power Button – Basket Pressure

Cylinder Re-phasing

To keep cylinders and machine level throughout the day, select a re-phasing option.

- Auto re-phase will automatically fully raise machine on an up-detent when the number of cycles is reached.
- Re-phase reminder will display a reminder to re-phase cylinders once the number of cycles is reached.

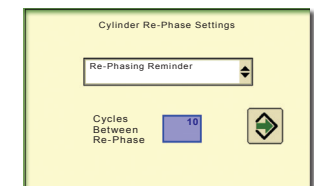
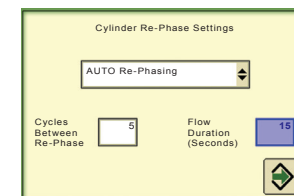

TruSet™ - 2230 Level Lift Field Cultivator QUICK REFERENCE GUIDE

Creating Prescription

- Use John Deere Operations Center to create the Prescription.
- Use Soil Survey Data, Previous Operations, or Freehand Drawing Tools to create management zones in areas that may require different levels of tillage.

Some examples are:

- Side hills and hill tops (HEL)
- Bottom ground
- Areas of high yield
- Grain cart traffic areas
- Headlands/end rows
- Certain soil types
- Use your farms "typical operating depths and pressure" as a baseline. Increase or decrease the values in appropriate areas.
- For Operations not being controlled by a prescription, those areas can be run in constant and can be adjusted utilizing the "Setpoint Input" or "Presets".

A prescription offset changes the prescribed value by the amount entered. Arrow softkeys will also increment the offsets accordingly. This offset applies to all zones within a field for the respective operation. A negative value will shallow the operation.

- If you have a "Section Control Activation" for your display, Section Control can be used to automatically raise the machine, when crossing boundaries.

| Operation: | Shank | Basket |
|------------------------|--|---------|
| | 4.0 | 400 |
| Minimum | 0" | 0 psi |
| Maximum | 5-6" | 900 psi |
| Additional Constraints | 6" maximum for Perma-Loc™ sweeps. 5" for bolt-on sweeps. | |

Input Box grayed out, when the input is Prescription

Shank Depth Settings

| Increment | | Setpoint | |
|--|----------|----------------------------|----------|
| Up | 0.5 (in) | Upper | -6 (in) |
| Down | 0.5 (in) | Lower | 2.5 (in) |
| | | Displayed Delay Adjust | |
| | | -2.5 (in) | |
| Prescription Offset: 0.0 | | Setpoint Input: Display Rx | |
| Section Control Enable: <input type="checkbox"/> | | | |

Prescription Offset Field

Section Control Enable checkbox

Disengage Single-Point Depth Control-TruSet™ Machines

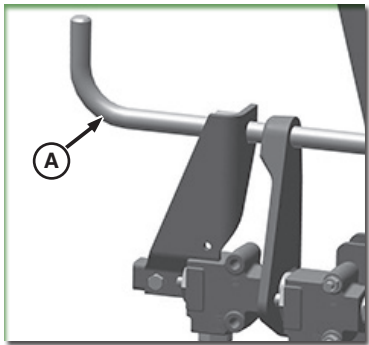

Verify single-point depth control is disengaged to allow TruSet™ depth control system to function properly. Rotate the crank (A) fully clockwise.

Set Up Tractor Hydraulics-All Machines

CAUTION: Do not operate SCV I in continuous. Operating SCV I in continuous can cause machine to unfold unexpectedly during transport causing serious injury or death to you or others.

Check hydraulic oil level. Fill if necessary. Set SCV flow rates and detent times as shown in table.

IMPORTANT: 5-Section only—In order for wings to be folded and unfolded, the warning light connector must be connected to tractor. If left unconnected, wings will not fold or unfold. In order for wings to be folded and unfolded, set SCV II flow control knob to 10 and verify that tractor is running at 1800 rpm.

IMPORTANT: Maintain SCV II power during folding and unfolding to fully extend or retract wing wheels. Never allow wings to float down with gravity.

| SCV | Function | Flow | Detent Time |
|-----|------------------------------|------|-------------|
| I | Depth Control | 10 | 5 s |
| II | Wing Fold/Unfold | 10 | 90 s |
| III | - | - | - |
| IV | - | - | - |
| V | Rolling Basket Down-Pressure | 2 | Continuous |