

310 SE



Everything a 14-foot backhoe should be – and more

The 310SE isn't just another backhoe in an already crowded class. If you thirst for power, this new digging machine will quench your need. And will likely exceed your expectations.

Bucket to bucket, high-strength structures and enhanced hydraulics make the 310SE our most powerful 14-footer ever. To be sure, backhoe and loader reach, lift, and crowd are impressive. But for all its muscle, the high-torque turbocharged 80-hp 310SE is also noticeably nimble. Transport and cycle speeds are quick. And its stable platform and aggressive drivetrain exercise good road manners, taking both potholes and rolling hills in stride.

As with all Deere backhoes, the 310SE is loaded with safety features. From bypass-start protection to the automatic park brake, fan guard to neutral-start reverser – nobody offers more to help keep you safe.

Perhaps best of all, the 310SE is backed by Deere dealers with well-stocked parts inventories and factory-trained technicians in more than 400 North American locations. Rest assured, nobody supports you better.

High-torque diesel, tight torque-converter match, and aggressive gearing let this backhoe accelerate quick, road fast, and climb steep grades.

Looking for a 14-foot backhoe with extra ability, comfort, and after-sale support? We've got your number – 310SE. To find out more about it, turn the

Curved knee loader and unique bucket linkage provide exceptional reach and smooth self-leveling. For quick and easy truck loading with less spillage.

page and read on. Then go see your John Deere dealer for a hands-on demo – and more.

PowerCurve™ boom and high-pressure hydraulics deliver impressive reach, lift, crowd power, and strength.



Features like these make this Deere a real horse

Go ahead – place pipe, breakout blacktop, dig deep straight walls. With excavator-style boom, bucket, and hydraulics, the 310SE is up to the task.

Crowd power, swing torque, and boom and dipperstick lift are impressive. Excavator-style high-pressure hydraulics are powerful and quick, and easy-to-operate controls smoothly blend functions so you can do your best work.

The Power Curve™ boom's digging geometry has all the angles covered, providing additional reach both near and far – for better up-close visibility and less repositioning. Makes loading trucks easier, too.

But it's not just the shape of the boom that makes this backhoe different. An exclusive bucket link provides 190-degree rotation, letting you go from

power-dig to truck-loading position without pulling a pin. Perfect for nearly effortless vertical-wall excavations, and full buckets with less spillage.



Available quick-coupler lets you change buckets and attachments easily. Requires no special pins, tools, or buckets. Accommodates Cat, Case, and Deere C- and D-Series buckets, as well.



Two levers are standard; three- or four-lever controls can be factory or field installed. Low effort and smooth response are yours regardless of configuration.



Boom starts wide at the base and narrows to 9 inches through the line-of-sight. Unlike the large "dorsal fin" on other excavator-style booms, the 310SE's compact cylinders share a single-pin attaching point that doesn't impair side-swing visibility, either.



Available extendible dipperstick adds 3 1/2 feet of digging depth and reach. Outer box extends, enabling it to firmly grasp objects between the bucket and box gripper teeth while retracting or extending. Wear strips are easy to lube, simple to replace.

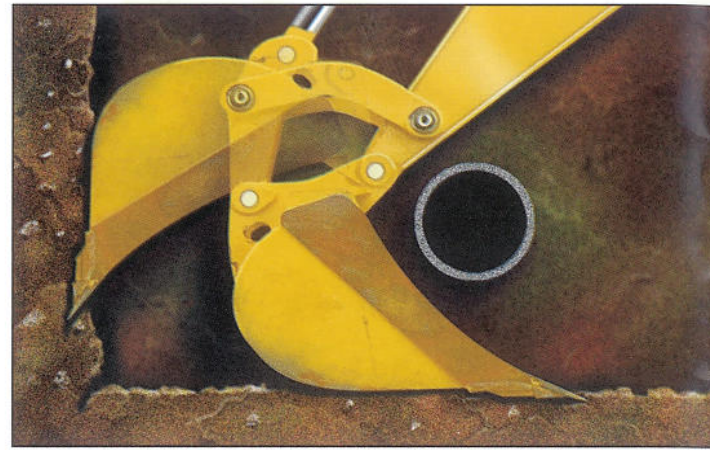

310SE's exclusive bucket linkage provides 190-degrees of rotation, making vertical wall excavations a lot easier. What's more, excavator-style curved sidecutters enable you to dig around buried pipe, reducing handwork. Bucket and linkage pins are lubricated for long life.

Boom and dipperstick are box-constructed of high-strength steel for heavy-duty durability. Forked top and bottom, and large pins, provide extra beef in this high-stress area. 

Easy-to-operate boom lock secures the backhoe in a vertical position for smooth transport. Rubber bumper keeps the boom snug and virtually rattle-free. 

Crane heavy objects? With 5,046 pounds of dipper lift, 310SE can handle it. Hydraulic circuit checks reduce drift. Buckets are equipped with lift eyes.

Rearward-angled 10-foot-wide stabilizers and no-drift cylinders provide rock-solid stability. Optional reversible pads have an aggressive side for soft terrain and a rubber side for hard surfaces. 



The best loader on any backhoe is now even better



Available mechanical-front-wheel-drive provides extra power and traction to heap the bucket regardless of what's underfoot. Its limited-slip design automatically transfers up to 80 percent of available power to the wheel with the best traction.

Transmission disconnect switch diverts full engine power to the hydraulics for faster loading.



Short-throw single lever puts low-effort control of the boom and bucket in the palm of your right hand.

We could have been content to leave well-enough alone. After all, the loader on our backhoes was considered by many to be the industry's best. Good as it was, however, we saw some room for improvement. And you're the beneficiary.

The 310 SE's robot-welded boom is constructed of laser-cut, high-tensile steel for superior strength without excess weight. Its one-piece continuous curve box-section design eliminates the need for additional plating in the knee area. And a large-diameter reinforced crosstube adds rigidity to resist torsional stress.

What's more, the curved knee accommodates tall tires for better flotation and increased ground clearance. Provides exceptional reach, too, enabling you to easily dump to the center of most trucks.

An excellent lift-to-crowd match and smooth combined-function metering make filling the bucket nearly effortless. And the refined linkage provides smooth self-leveling and control for full buckets and less spillage. Makes grading easier, too.



No more shaking the bucket in an attempt to position the load. Superior reach enables the 310SE to dump to the center of the truck for easier loading and fast cycles.

"Torque tube" spallsheet construction resists bending. C-shape backwall fills easily and resists packing. Long-lip retains more material. Bolt-on cutting edge, full-length skid shoes, and built-in lift eyes are included.



Bucket level indicator is within your line-of-sight. Nearby automatic return-to-dig switch is well-protected, yet easily accessible. Hydraulic self-leveling and float are also standard.



Tight torque converter match, impressive torque reserve, and excellent lift-to-crowd match make the 310SE a responsive and aggressive loading tractor.

An available quick-coupler lets you couple and release buckets and attachments with a flick of a switch.



Inside beats the heart of a Deere

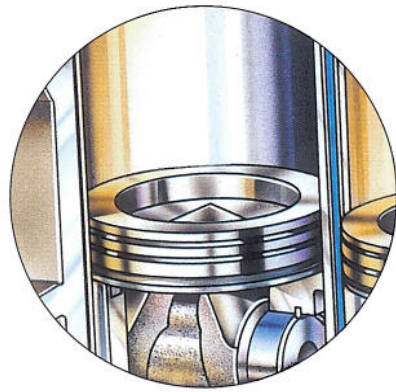

Free-breathing cross-flow cylinder head, specially shaped pistons, and contoured valves increase intake and exhaust flows for maximum power output and top fuel efficiency.

Advanced PowerTech™ diesel meets all worldwide emission standards for off-road engines – so the 310SE can go to work anywhere these rigid standards exist.

A 4-speed fully synchronized collar-shift transmission and electric actuated reverser provide smooth moves and direction changes.

Transmission is mounted directly to the engine for superior balance; has its own filter for long life.

Individually replaceable, spin-cast, wet-type cylinder liners dissipate heat for reduced ring wear and oil breakdown. High-ring pistons provide high compression, three low-friction rings deliver superior oil control.

Deere-built 4.5 L turbo-charged diesel packs a whopping 42 percent torque reserve. What's more, this long-stroke diesel actually digs down and delivers more than its rated horsepower at 1800 rpm .

Open-center hydraulic system and heavy-duty tandem-section gear-type pump blends good metering characteristics with low effort for smooth control. Second pump is unloaded when not needed to maximize power and fuel efficiency.

Jet-spray nozzles bathe the bottom sides of pistons with cooled oil for longer life.

Independent of the service brakes, the wet-disk parking brake automatically engages whenever the engine stops. Effective on both front and rear wheels (with MFWD), it also neutralizes the reverser so the 310SE can't be operated with the brake engaged. Plus, it never needs adjusting.

Self-adjusting and fully modulated so they require little effort and no maintenance, these chatter-free inboard mounted multiple wet-disk brakes also self-equalize for no-swerve braking in traffic.

Available industrial-strength MFWD is totally sealed and features a unique offset differential for superior ground clearance. Its limited-slip design delivers true all-wheel-drive.

High torque rise, tight torque converter match, and aggressive gearing give 310SE a powertrain that accelerates fast and climbs grades, even in 4th gear.

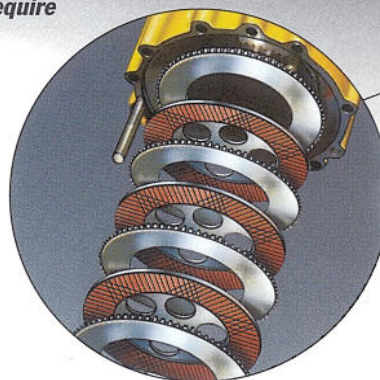

Planetary final drives distribute loads over three gears and are sealed in a cooling oil bath for long life and trouble-free performance.

Differential lock can be engaged on-the-go to improve traction in poor underfoot conditions.

Rear axle bearings are self-lubricating so you'll never need to grease this frequently overlooked service point.

Hear today, hear tomorrow

Pounding hammers, screaming exhausts, clanging backup alarms – if you're looking to get away from it all, you've come to the right place. At less than 76 dB(A), the 310SE's cab is the quietest. It's a fatigue-reducing advantage you'll appreciate today – and for years to come.

When it comes to visibility, the 310SE is also clearly the leader. Floor-to-ceiling tinted front glass, huge side and rear windows, and narrow, well-positioned ROPS posts provide virtually unobstructed all-around visibility.

Short-throw, low-effort levers are at your fingertips. And the fully padded, thick-cushioned seat and available tilt steering wheel fully adjust.

Even "little extras" are yours for no extra. There's a place for securing your Thermos and another for cradling your coffee cup. Also, a hook for your jacket, a slot for your operator's manual or paperwork, and an in-cab rearview mirror, to list just a few.

Who has the best-dressed backhoe in the 14-foot class? You do, if you're running a 310SE.

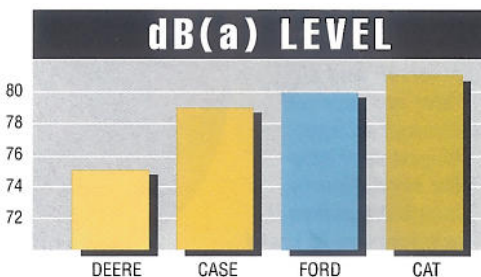

A flip of a switch is all it takes to engage or disengage the secondary brake. Independent of the service brakes, it automatically engages whenever the engine stops.



Electronic monitor and optional gauges can be read at-a-glance from either operating position. Console also houses seat belt warning and ignition, as well as climate controls.



Huge doors open wide (right-side optional) and out of the way of oncoming traffic. Large, self-cleaning steps and convenient handholds allow easy entrance/exit.

40,000 Btu/hr. climate-control system blends fresh air for effective defrosting, heating, and cooling (air-conditioning available). Cab pressurization helps keep out dust.



Engage the differential lock on-the-go with a touch of your toe. This standard feature equalizes power to the rear wheels for increased traction in slick conditions or when moving a heavy load.

Electric reverser lever allows fingertip direction changes. Built-in detents give smooth, positive control and neutral-start switch prevents accidental machine movement. Reverse is 10 percent faster than forward for fast cycles.

Available full-suspension cloth-covered armchair with flip-up arms and front-mount controls adjusts 8 ways. Standard non-suspension vinyl-covered seat features the same sculpted deep-cushioning and single-hand control of simultaneous slide and swing.

Directional automotive-type vents provide comfortable ventilation and effective defogging.

MFWD switch is uniquely shaped and within easy reach for no-look on/off.

Maintenance is easy as 1, 2, 3...

This lockable non-binding sliding door allows easy access to engine and transmission dipsticks, fill tubes, and fuel filter. The engine coolant reservoir and air filter are serviced through a large hinged door atop the hood. Nearby lube bank makes it unnecessary to crawl under the tractor to grease the axle pivot.



1.

2.

3.

Eye-level sight gauge provides a quick contamination-free check of the hydraulic oil level. Check it on the way to the seat, or while you fill the fuel tank.

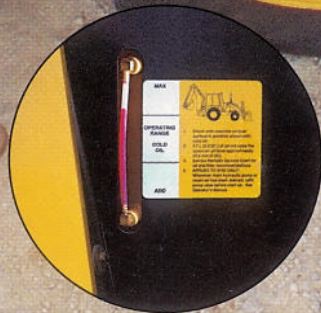

Some mornings, it's difficult enough just getting yourself ready for work. Those are the days when you'll especially appreciate the 310SE.

Most daily and periodic service points are grouped and ground accessible, making checks, additions, or changes quick and easy to accomplish. Vertical spin-on filters, lifetime-lubricated outer axle bearings, a front-axle grease bank, and numerous other convenience features help make maintaining the 310SE as easy as... well, you get the idea.

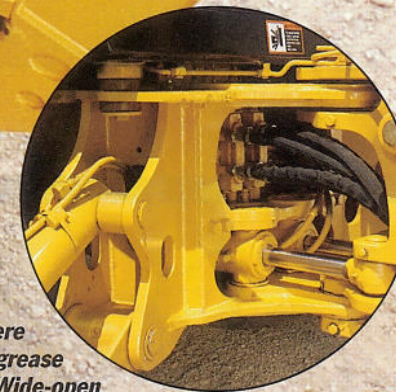

Zerks are positioned where you can get a grease gun on them. Wide-open swing frame allows easy access to the hydraulic valve and lines. External boom cylinder and hoses are also easier to service. Flat-face O-ring seal couplings virtually eliminate annoying and costly leaks.

We've got what it takes to keep you working

With its new heavy-duty loader, excavator-style backhoe, and enhanced hydraulic system, it doesn't take a lot of expensive options to widen the appeal of your 310SE.

Start with a loader or backhoe quick-coupler that lets you change attachments in seconds. Add a "wet kit" to deliver high-flow hydraulic power out back. Or even a solenoid-controlled low-flow auxiliary valve for hand-held or cylinder-actuated attachments. What you have now is a highly versatile machine that can handle virtually any hydraulic-powered attachment.

But regardless of how many "bells and whistles" it may have, no backhoe is any better than the support behind it. That's why every 310SE is backed by a large network of dealers with well-stocked parts inventories, factory-trained technicians, and comprehensive support programs. Add a one-year warranty, historically high resale value, and low owning and operating costs and the reasons for running a John Deere backhoe are better than ever.

Scan this page for an idea of the kind of attachments available for the 310SE. Then get to your John Deere dealership and get to work.



OTHER

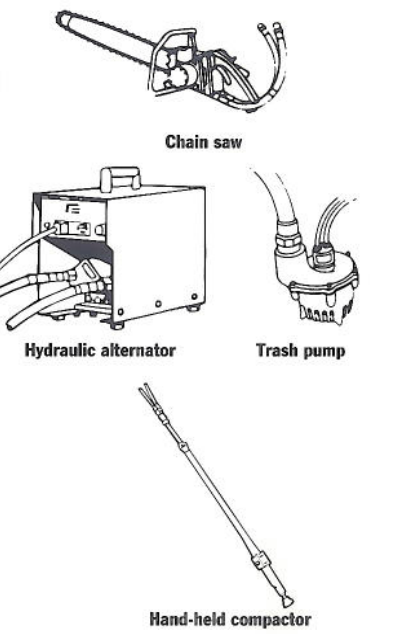
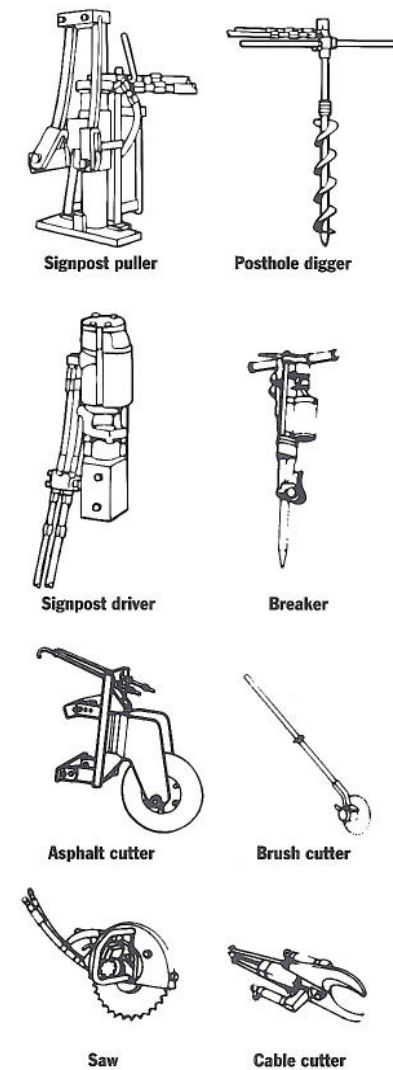

LOADER

BACKHOE

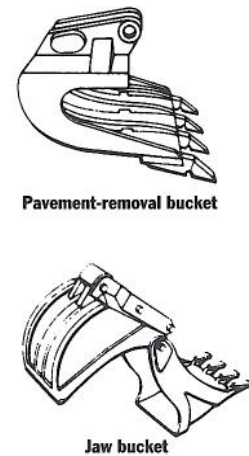
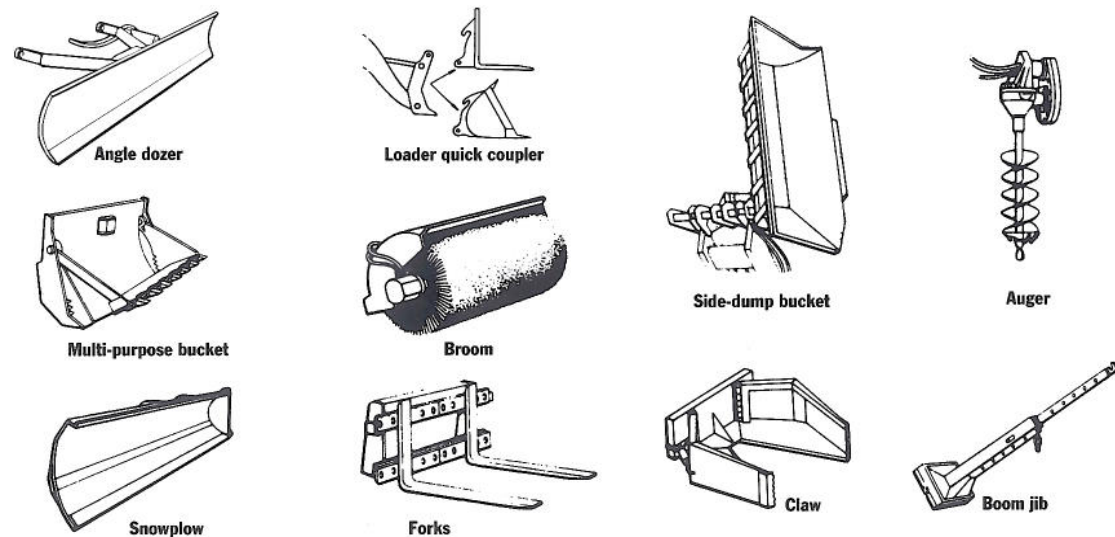

ENGINE		310SE	
Type	John Deere 4045T – Turbocharged		
Rated power @ 2,200 rpm	88 SAE gross hp (66 kW) 80 SAE net hp (60 kW)		
Cylinders	4		
Displacement	276 cu. in. (4.524 L)		
Fuel consumption, typical	1.3 to 2.3 gal./hr. (4.9 to 8.7 L/h)		
Torque rise	42 percent		
Maximum net torque	271 lb.-ft. (368 Nm)		
Lubrication	pressure system with spin-on filter and cooler		
Air cleaner	dual stage dry type with safety element and precleaner		
Electrical system	12 volt with 65-amp alternator		
Sucker-type cooling fan			
TRANSMISSION		four-speed, helical cut gear, collar shift transmission synchronized in all gears with hydraulic reverser	
Torque converter, single stage, dual phase with 2.63:1 stall ratio	11 in. (280 mm)		
Travel speeds with 19.5L-24 rear tires	<i>Forward</i>	<i>Reverse</i>	
Gear 1	3.6 mph (5.8 km/h)	4.0 mph (6.4 km/h)	
Gear 2	5.9 mph (9.5 km/h)	6.6 mph (10.6 km/h)	
Gear 3	14.4 mph (23.2 km/h)	16.1 mph (25.9 km/h)	
Gear 4	24.4 mph (39.3 km/h)	27.2 mph (43.8 km/h)	
FINAL DRIVES		heavy-duty, inboard planetary final drives evenly distribute shock loads over three gears	
BRAKES		hydraulic wet disk, mounted inboard, self adjusting and self equalizing	
CAPACITIES			
Fuel tank (with ground level fueling)	36 gal. (136 L)		
Engine coolant	17 qt. (16 L)		
Engine oil including filter	9 qt. (8.5 L)		
Torque converter and transmission	15 qt. (14 L)		
Hydraulic system	24 gal. (91 L)		
Rear axle	3.5 gal. (13 L)		
Mechanical-front-wheel-drive axle	2.3 gal. (8.5 L)		
STEERING		hydrostatic power steering and emergency steering conform to ISO5010	
Non-powered axle			
Curb turning radius with brakes	11 ft. 9 in. (3.57 m)		
Without brakes	13 ft. 3 in. (4.04 m)		
Bucket clearance circle with brakes	31 ft. 6 in. (9.61 m)		
Without brakes	34 ft. 7 in. (10.55 m)		
Steering wheel turns, stop to stop	2.3 to 3.0		
Mechanical-front-wheel-drive			
Curb turning radius with brakes	10 ft. 11 in. (3.34 m)		
Without brakes	13 ft. 8 in. (4.17 m)		
Bucket clearance circle with brakes	29 ft. 9 in. (9.07 m)		
Without brakes	35 ft. 3 in. (10.74 m)		
Steering wheel turns, stop to stop	2.5		
Axle oscillations stop to stop, both axles	22 degrees		
Axle ratings (SAE J43)			
Front	18,860 lb. (8555 kg)		
Rear	13,670 lb. (6200 kg)		
HYDRAULIC SYSTEM			
System	open center		
Pressure			
Backhoe	3,625 psi (25 000 kPa)		
Loader	3,000 psi (20 700 kPa)		
Pump	gear type, tandem with unloader		
Flow @ 2,200 rpm			
Backhoe	36 gpm (136 L/min.)		
Loader	28 gpm (106 L/min.)		
Filter, return oil	10-micron, spin-on enclosed replaceable element		

CYLINDERS		310SE		
	<i>Bore</i>	<i>Stroke</i>	<i>Rod</i>	
Loader boom (2)	3.15 in. (80 mm)	31.1 in. (790 mm)	1.97 in. (50 mm)	
Loader bucket (1)	3.15 in. (80 mm)	33.7 in. (856 mm)	1.77 in. (45 mm)	
Backhoe boom (1)	4.72 in. (120 mm)	31.3 in. (795 mm)	2.20 in. (56 mm)	
Backhoe crowd (1)	4.53 in. (115 mm)	23.9 in. (607 mm)	2.48 in. (63 mm)	
Backhoe bucket (1)	3.54 in. (90 mm)	31.9 in. (810 mm)	2.20 in. (56 mm)	
Backhoe swing (2)	3.54 in. (90 mm)	10.9 in. (278 mm)	1.97 in. (50 mm)	
Backhoe extendable dipperstick (1)	2.76 in. (70 mm)	42.0 in. (1067 mm)	1.77 in. (45 mm)	
Backhoe stabilizer (2)	3.54 in. (90 mm)	19.7 in. (500 mm)	1.97 in. (50 mm)	
Steering (1) non-powered axle	1.97 in. (50 mm)	9.49 in. (241 mm)	0.98 in. (25 mm)	
Steering (1) MFWD	2.56 in. (65 mm)	8.27 in. (210 mm)	1.42 in. (36 mm)	
TIRES		<i>Rear</i>	<i>Front</i>	
With non-powered front axle	16.9-24, 8 PR R4	11L-15, 8 PR F3		
	19.5L-24, 8 PR R4	11L-16, 12 PR F3		
With mechanical-front-wheel-drive	19.5L-24, 8 PR R4	12.5/80-18, 10 PR		
SAE OPERATING WEIGHTS				
Standard	13,500 lb. (6123 kg)			
Cab adds	580 lb. (263 kg)			
Mechanical-front-wheel-drive with tires adds	485 lb. (220 kg)			
Extendable dipperstick excluding required counterweight adds	490 lb. (222 kg)			
Optional 400-lb. counterweight adds	400 lb. (181 kg)			
Optional 650-lb. counterweight adds	650 lb. (295 kg)			
Optional 250-lb. bolt-on counterweight adds	250 lb. (113 kg)			
Backhoe bucket coupler adds	138 lb. (63 kg)			
See backhoe and loader performance data for bucket weights.				
LOADER BUCKETS		<i>Width</i>	<i>Heaped Capacity</i>	<i>Weight</i>
Heavy-duty long lip	86 in. (2180 mm)	1.25 cu. yd. (0.96 m ³)	875 lb. (397 kg)	
	92 in. (2340 mm)	1.30 cu. yd. (1.00 m ³)	1,050 lb. (476 kg)	
Multipurpose	86 in. (2180 mm)	1.00 cu. yd. (0.76 m ³)	1,450 lb. (658 kg)	
	92 in. (2340 mm)	1.25 cu. yd. (0.96 m ³)	1,550 lb. (703 kg)	
Auxiliary cutting edge and skid shoes are standard on all buckets.				
BACKHOE PERFORMANCE		<i>With Standard Backhoe*</i>	<i>With Extendable Dipperstick*</i>	
		<i>Retracted</i>	<i>Extended</i>	
Digging force, bucket cylinder	11,990 lb. (53.3 kN)	12,158 lb. (54.1 kN)	12,158 lb. (54.1 kN)	
Digging force, crowd cylinder	8,090 lb. (36.0 kN)	7,796 lb. (34.7 kN)	5,628 lb. (25.0 kN)	
Swing arc	180 degrees	180 degrees	180 degrees	
Operator control	two levers	right foot treadle	right foot treadle	
Bucket rotation	190 degrees	190 degrees	190 degrees	
Stabilizer angle rearward	18 degrees	18 degrees	18 degrees	
Leveling angle	14 degrees	14 degrees	14 degrees	
*Backhoe specifications are with 24 in. x 7.5 cu. ft. (610 mm x 0.21 m ³) bucket.				
BACKHOE BUCKETS		<i>Width</i>	<i>Capacity</i>	<i>Weight</i>
Standard duty	24 in. (610 mm)	7.5 cu. ft. (0.21 m ³)	350 lb. (159 kg)	
Heavy duty with lift loop	12 in. (305 mm)	3.3 cu. ft. (0.09 m ³)	295 lb. (134 kg)	
	18 in. (457 mm)	5.1 cu. ft. (0.14 m ³)	335 lb. (152 kg)	
	24 in. (610 mm)	7.5 cu. ft. (0.21 m ³)	400 lb. (181 kg)	
	24 in. (610 mm)	8.8 cu. ft. (0.25 m ³)	420 lb. (191 kg)	
	30 in. (762 mm)	10.0 cu. ft. (0.28 m ³)	445 lb. (202 kg)	
	36 in. (914 mm)	12.5 cu. ft. (0.35 m ³)	510 lb. (231 kg)	
Severe duty with lift loop	18 in. (457 mm)	5.1 cu. ft. (0.14 m ³)	362 lb. (164 kg)	
	24 in. (610 mm)	7.5 cu. ft. (0.21 m ³)	425 lb. (193 kg)	
	24 in. (610 mm)	8.8 cu. ft. (0.25 m ³)	455 lb. (206 kg)	
	30 in. (762 mm)	10.0 cu. ft. (0.28 m ³)	475 lb. (215 kg)	
Ditch cleaning	36 in. (914 mm)	12.5 cu. ft. (0.35 m ³)	510 lb. (231 kg)	

*Lift capacities are over-end values in lb. (kg) according to SAE J31. Figures listed are 87% of the maximum lift force available. Base vehicle includes counterweight.

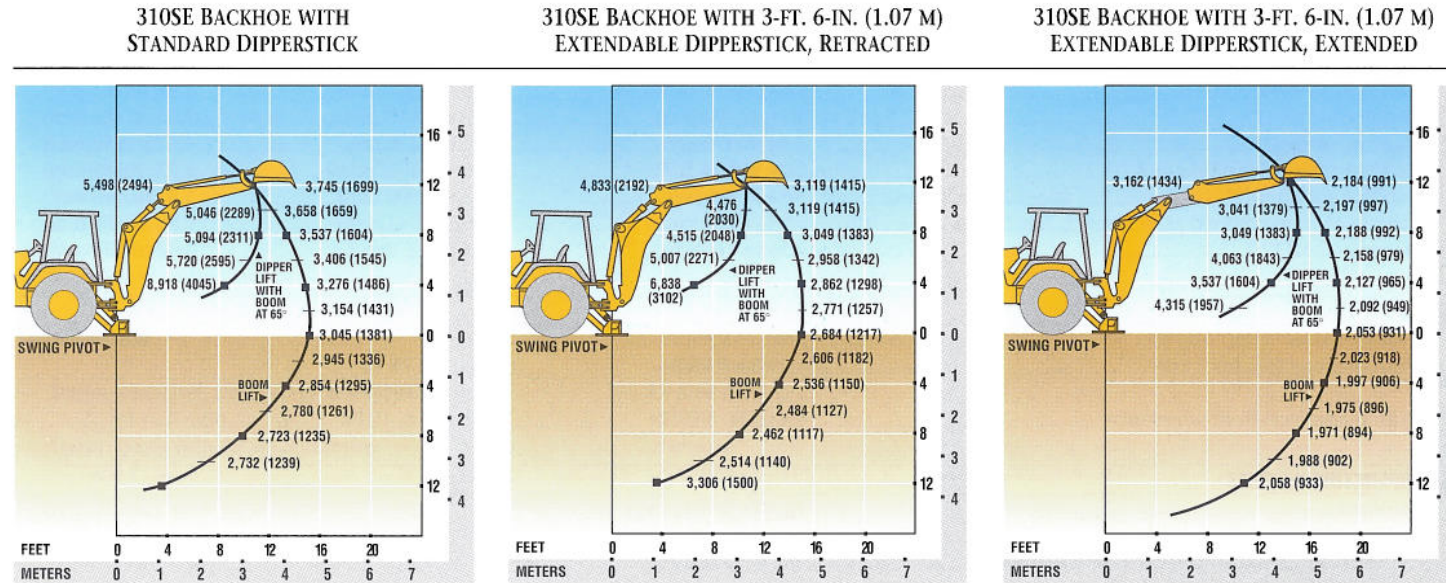

DIMENSIONS (SEE PAGE 19.)

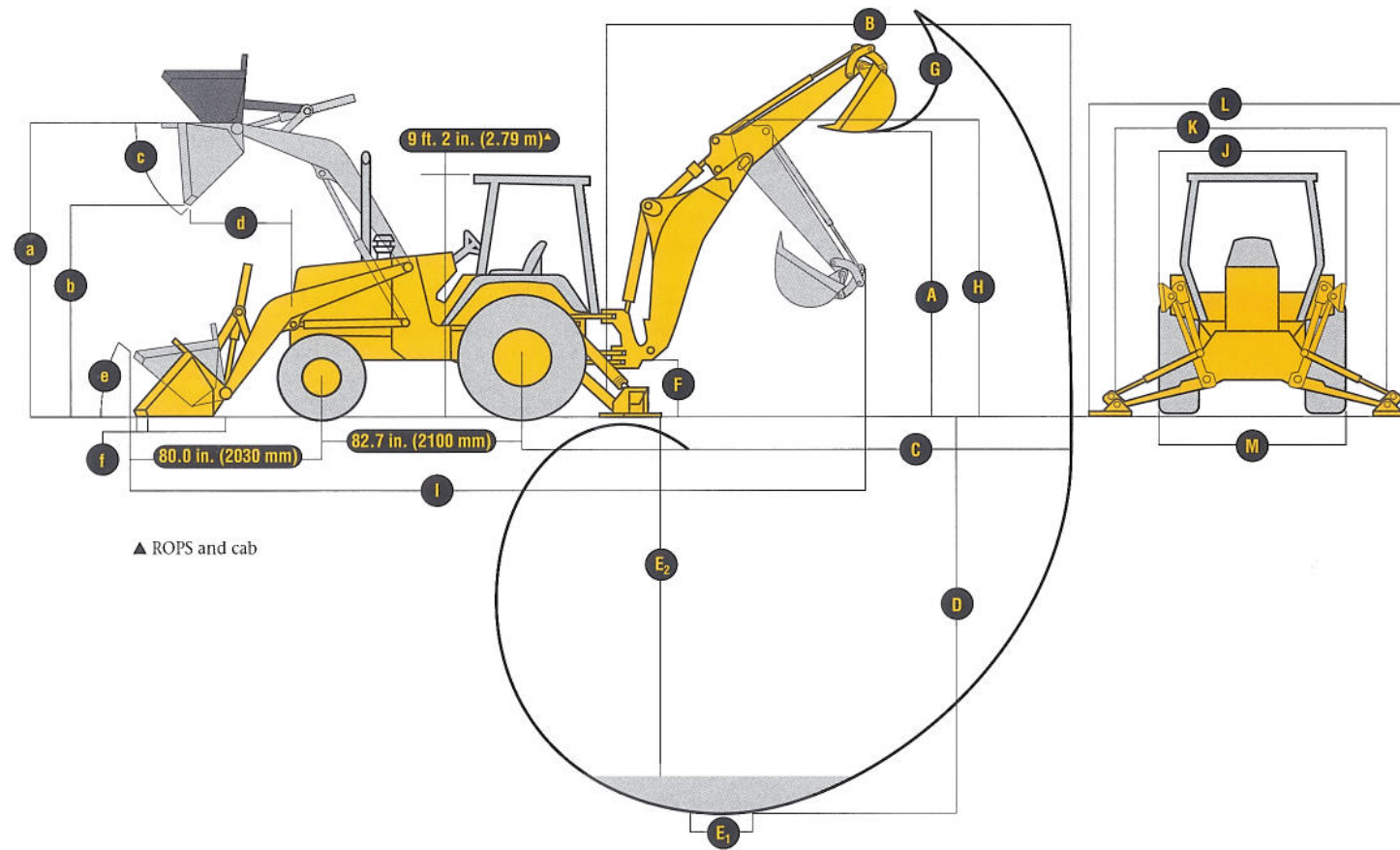

BACKHOE

310SE

	With Standard Backhoe*	With Extendable Dipperstick*	
		Retracted	Extended
A Loading height, truck loading position	11 ft. 3 in. (3.43 m)	11 ft. 7 in. (3.53 m)	14 ft. 1 in. (4.29 m)
B Reach from center of swing pivot	18 ft. 3 in. (5.56 m)	18 ft. 7 in. (5.66 m)	21 ft. 11 in. (6.68 m)
C Reach from center of rear axle	21 ft. 9 in. (6.63 m)	22 ft. 1 in. (6.73 m)	25 ft. 4 in. (7.72 m)
D Maximum digging depth	14 ft. 6 in. (4.42 m)	14 ft. 11 in. (4.55 m)	18 ft. 5 in. (5.61 m)
E Digging depth (SAE):			
(1) 2-ft. (610 mm) flat bottom	14 ft. 4 in. (4.37 m)	14 ft. 9 in. (4.50 m)	18 ft. 3 in. (5.56 m)
(2) 8-ft. (2440 mm) flat bottom	13 ft. 4 in. (4.06 m)	13 ft. 9 in. (4.19 m)	17 ft. 6 in. (5.33 m)
F Ground clearance, minimum	13 in. (330 mm)	13 in. (330 mm)	13 in. (330 mm)
G Bucket rotation	190 degrees	190 degrees	190 degrees
H Transport height	11 ft. 6 in. (3.51 m)	11 ft. 5 in. (3.48 m)	11 ft. 5 in. (3.48 m)
I Overall length, transport	23 ft. 6 in. (7.16 m)	23 ft. 6 in. (7.16 m)	23 ft. 6 in. (7.16 m)
J Stabilizer width – transport with ROPS	7 ft. 2 in. (2.18 m)	7 ft. 2 in. (2.18 m)	7 ft. 2 in. (2.18 m)
K Stabilizer spread – operating	10 ft. 2 in. (3.10 m)	10 ft. 2 in. (3.10 m)	10 ft. 2 in. (3.10 m)
L Stabilizer overall width – operating	11 ft. 7 in. (3.53 m)	11 ft. 7 in. (3.53 m)	11 ft. 7 in. (3.53 m)
M Width over tires	86 in. (2.18 m)	86 in. (2.18 m)	86 in. (2.18 m)

*Backhoe specifications are with 24 in. x 7.5 cu. ft. (610 mm x 0.21 m³) bucket.

LOADER PERFORMANCE WITH BUCKET OPTIONS

	1.25 cu. yd. (0.96 m ³) Heavy-Duty Long Lip	1.30 cu. yd. (1.00 m ³) Heavy-Duty Long Lip	1.00 cu. yd. (0.76 m ³) Multipurpose	1.25 cu. yd. (0.96 m ³) Multipurpose
Operator control	single lever	single lever	single lever	single lever
Breakout force	7,933 lb. (30.4 kN)	8,900 lb. (39.6 kN)	8,325 lb. (37.0 kN)	8,300 lb. (36.9 kN)
Lifting capacity, full height	6,240 lb. (2835 kg)	6,150 lb. (2790 kg)	5,900 lb. (2676 kg)	5,800 lb. (2631 kg)
a Height to bucket hinge pin, maximum	11 ft. 2 in. (3.40 m)	11 ft. 2 in. (3.40 m)	11 ft. 2 in. (3.40 m)	11 ft. 2 in. (3.40 m)
b Dump clearance, bucket at 45 degrees	8 ft. 2 in. (2.59 m)	8 ft. 8 in. (2.64 m)	8 ft. 7 in. (2.62 m)	8 ft. 7 in. (2.62 m)
c Bucket dump angle, maximum	45 degrees	45 degrees	45 degrees	45 degrees
d Reach at full height, bucket at 45 degrees	31.9 in. (809 mm)	30.1 in. (765 mm)	32.2 in. (818 mm)	32.2 in. (818 mm)
e Rollback angle at ground level	40 degrees	40 degrees	40 degrees	40 degrees
f Digging depth below ground, bucket level	5.8 in. (147 mm)	8.1 in. (206 mm)	7.3 in. (185 mm)	7.3 in. (185 mm)
Raising time to full height	4.9 sec.	4.9 sec.	4.9 sec.	4.9 sec.
Bucket dump time	1.1 sec.	1.1 sec.	1.1 sec.	1.1 sec.
Bucket lowering time (power down)	1.9 sec.	1.9 sec.	1.9 sec.	1.9 sec.

LIFT CAPACITY WITH QUICK COUPLER/FORKS

- A'** Maximum height 4,178 lb. (1897 kg)
- B'** Maximum reach 6,191 lb. (2810 kg)
- C'** At ground line 8,232 lb. (3737 kg)
- D'** Below ground line 4.4 in. (112.7 mm) to bottom of tine / 2.7 in. (68.3 mm) to top of tine

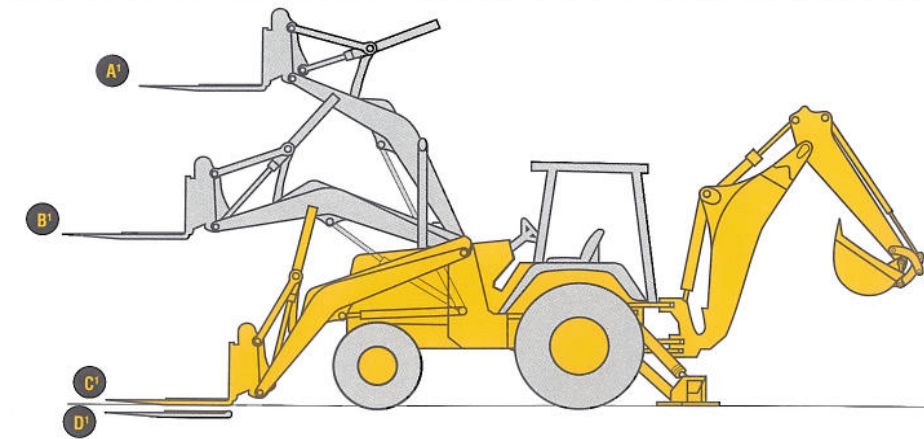

	310SE		310SE		310SE
ENGINE					
John Deere Model 4045T – 4.5 liter, 80 SAE net hp turbocharged, isolation mounted	●	Heavy duty with lift loops	■	Key start switch with electric fuel shutoff	●
Vertical spin-on engine oil filter	●	Severe duty with lift loops	■	Hourmeter, illuminated electric	●
Spin-on John Deere fuel filter with water separator	●	Backhoe bucket coupler for "C" and "D" series John Deere buckets, Case buckets, and Cat buckets	■	Tachometer/hourmeter, illuminated electric	■
Oil-to-water engine oil cooler	●	Extendable dipperstick, 3 ft. 6 in. extension	■	Fuel gauge, illuminated electric	●
Antifreeze, -34°F (-37°C)	●	Auxiliary backhoe valve for swingers, thumbs, etc.	■	Gauge package, illuminated electric	■
Coolant recovery tank	●	Auxiliary backhoe valve for hammers, compactors	■	Engine coolant temperature / Transmission oil temperature / Alternator volts / Fuel gauge	●
Serpentine belt with automatic belt tensioner	●	Auxiliary backhoe plumbing for hammers, compactors	■	Monitor system with audible and visual warning	●
Sucker-type cooling fan	●	SAE controlled load lowering device valves	■	Engine air filter restriction indicator / Alternator indicator / Engine coolant temperature indicator with audible warning / Engine oil pressure indicator with audible warning / Hydraulic filter restriction indicator / Torque converter oil temperature indicator / Parking brake on/off indicator with audible warning / Seat belt indicator / Mechanical-front-wheel-drive on/off indicator / Beacon on/off indicator	●
Enclosed safety fan guard	●	LOADER		Seats and seat belts	●
High ambient temperature engine cooling	■	Hydraulic self leveling	●	Non-suspension vinyl swivel seat without armrests	●
Dual element dry-type air cleaner	●	Return-to-dig feature	●	Suspension vinyl swivel seat with armrests and lumbar support	■
Muffler, underhood with curved-end exhaust stack	●	Single-lever control with electric clutch cutoff switch	●	Suspension fabric swivel seat with armrests and lumbar support	■
Chrome exhaust extension	■	Bucket-level indicator	●	Air suspension vinyl swivel seat with armrests and lumbar support	■
Electric ether starting aid	■	Loader boom service lock	●	Air suspension fabric swivel seat with armrests and lumbar support	■
Engine coolant heater, 1,000 watts	■	Auxiliary loader hydraulics with two-lever control	■	2-in. seat belt with retractors	●
POWER TRAIN		Loader front coupler	■	3-in. seat belt with retractors	●
Powershift transmission		Loader buckets		Cab	●
Torque converter with electrically actuated twist grip F-N-R in 1st through 4th gears	●	Less bucket, with bucket pins	■	Headliner	●
Transmission with powershift reverser and torque converter	●	Heavy-duty buckets with bolt-on cutting edge, skid plates, and lift loops	■	Dome light	●
Fully synchronized four forward, four reverse speeds / Isolation mounted to mainframe	●	Multipurpose buckets with bolt-on cutting edge, skid plates, and lift loops	■	Left cab door	●
Transmission oil cooler	●	HYDRAULIC SYSTEM		Right cab door	●
Vertical spin-on transmission filter	●	36 gpm (136 L/min.) tandem gear pump, open center system	●	Tinted safety glass	●
Electric forward-neutral-reverse control lever with neutral safety switch interlock	●	Independent hydraulic reservoir	●	Two front and one rear windshield wipers	●
Electric clutch cutoff on gearshift and loader levers	●	Hydraulic oil cooler	●	Front windshield washer	■
Differential lock, electric foot-actuated	●	"O"-ring face seal connectors	●	Fresh air intake heater/defroster/pressurizer 40,000 Btu/hr. (11.7 kW) heater	●
Planetary final drives	●	10-micron vertical spin-on filter	●	Air conditioning 26,000 Btu/hr. (7.6 kW) output / CFC-free R134a refrigerant	■
Hydraulic service brakes	●	ELECTRICAL		65-amp alternator	●
Inboard, wet multi-disc, self adjusting and self equalizing / Conform to SAE J1473	●	12-volt system	●	95-amp alternator	■
Parking/emergency brake with electric switch control	●	65-amp alternator	●	AM/FM/weatherband radio	■
Spring applied, hydraulically released wet multi-disc / Independent of service brakes / Conforms to SAE J1473	●	Single battery with 150-min. reserve capacity and 750 CCA	●	Ride control	■
Hydrostatic power steering with emergency manual mode	●	Dual batteries with 300-min. reserve capacity and 1,500 CCA	●	OVERALL VEHICLE	
Non-powered front axle	●	Positive terminal battery cover	●	One-piece unitized construction mainframe	●
Mechanical-front-wheel-drive with limited slip differential	●	Blade-type multi-fused circuits	●	Vehicle tie-downs, two front and one rear	●
Electric on/off control / Drive-shaft guard / Sealed axle	■	By-pass start safety cover on starter	●	Remote grease bank for front axle	●
Tires		LIGHTS		Rigid mounted front bumper	●
11L-15 F3 front tires	●	Two front halogen driving/work lights, 32,500 candlepower each	●	Front counterweights	■
11L-16 F3 front tires	■	Two additional front halogen work lights, 32,500 candlepower each	●	400 lb. (181 kg)	■
12.5/80-18 traction front tires	●	Two rear halogen work lights, 32,500 candlepower each	●	650 lb. (295 kg)	■
16.9-24 R4 rear tires	■	Two front and two rear turn signal/flashing	●	900 lb. (408 kg)	■
19.5L-24 R4 rear tires	■	Two rear stop and tail	●	1,150 lb. (522 kg)	■
Rear wheel spacers for use with chains	■	Two rear reflectors	●	1,400 lb. (635 kg)	■
BACKHOE		Rotating beacon	■	Fuel tank, 36 gal. (136 L), ground level fueling	●
Backhoe with standard dipperstick, 14 ft. 6 in. digging depth	●	OPERATOR'S STATION		Engine sideshields with sliding service access door	●
Backhoe controls		Modular-design ROPS/FOPS canopy with molded roof isolation mounted / Conforms to SAE J1040	●	Front grille screen	●
Two-lever (Deere) controls	●	Left and right front access	●	Vandal protection for instrument panel, engine access doors, and fuel tank	●
Three-lever (Case) controls	■	Slip-resistant steps and ergonomically located handholds	●	Reverse warning alarm	●
Four-lever (Ford) controls	■	Molded floor mat	●	Switchable to 97 dB(A) or 111 dB(A)	●
SAE excavator two-lever controls	■	Headliner	●	Dent-resistant rear fenders	●
Backhoe transport lock lever	●	Coat hook	●	Rear fender extensions	■
Swing lock pin stored in operator's station	●	Built-in beverage and Thermos® bottle holders	●	Front fenders*	■
Stabilizer valve with two-direction anti-drift valves	●	Built-in Operator's Manual storage compartment with manual	●	SMV emblem	■
Pivoting stabilizers		Interior rearview mirror	●	Rental decal kit	■
With dirt pads	●	Outside rearview mirrors	●	Special color paint*	■
With reversible pads	■	Hand throttle with fuel economy setting at 2,100 rpm	●	Quarter cab*	■
Stabilizer cylinder guards	■	Suspended foot throttle	●		
Backhoe buckets		Tilt steering	●		
Less bucket, with bucket pins	●	Horn	■		
Standard duty with lift loops	■				

KEY: ● Standard equipment ■ Optional or special equipment

*See your John Deere dealer for further information.



Net engine power is with standard equipment including air cleaner, exhaust system, alternator, and cooling fan, at standard conditions per SAE J1349 and DIN 70 020, using No. 2-D fuel at 35 API gravity. No derating is required up to 10,000 feet (3050 m). Gross power is without cooling fan.

Specifications and design subject to change without notice. Wherever applicable, specifications are in accordance with SAE standards. Except where otherwise noted, these specifications are based on a unit with 19.5L-24, 8 PR R4 rear tires, 11L-16, 12 PR F3 front tires, 1.12 cu. yd. (0.86 m³) loader bucket, and 24 in. x 7.5 cu. ft. (610 mm x 0.21 m³) backhoe bucket.

