

690D EXCAVATOR SPECIFICATIONS

Specifications and design subject to change without notice. Wherever applicable, specifications are in accordance with PCSA and SAE Standards. Except where otherwise noted, these specifications are based on a unit equipped with 42-in. (1067 mm) bucket, 24-in. (600 mm) track shoes, 2200 lb. (1000 kg) auxiliary counterweight, full fuel tank, 175 lb. (80 kg) operator and standard equipment.

Rated Power @ 2000 engine rpm:	SAE	DIN 6270B
Net	125 hp (93 kW)	93 kW
Gross	132 hp (98 kW)	

Net engine power is with standard equipment, including air cleaner, exhaust system, alternator, and cooling fan, at standard conditions per SAE J1349 and DIN 6270B using No. 2-D fuel @ 35 API gravity. No derating is required up to 10,000 feet (3050 m) altitude. Gross power is without cooling fan.

Engine: John Deere 6414T

Type	4-stroke cycle, turbocharged diesel
Bore and stroke	4.19 x 5.00 in. (106.5 x 127 mm)
No. of cylinders	6
Displacement	414 cu. in. (6.785 L)
Compression ratio	16.8 to 1
Maximum net torque @ 1300 rpm	420 lb-ft (569 Nm) (58 kg-m)

Lubrication Pressure system with full-flow filter
Cooling fan Suction type viscous drive
Air cleaner w/restriction indicator Dry
Electrical system 24-volt w/42-amp alternator
Batteries (two 12 volt) Reserve capacity: 160 minutes
An engine auto-idle system automatically lowers engine speed when control levers are in neutral. An auto-idle cancel switch is provided

Hydraulic System: Closed Center

Two variable-displacement axial-piston pumps with load-sensing and constant torque control in tandem are directly coupled to engine. Main control valves are pressure and flow compensated to provide independent and load independent combined operation for all functions. Control valves are field flow adjustable to provide optimum control and function speed. A pad is provided for auxiliary function valve attachment. Easy to reach flow control switch. Actuation slows propel and implement circuits for more precise control.

Main pumps	2 variable-displacement axial piston
Minimum flow	2 x 2.6 gpm (2 x 10 L/min)
Maximum rated flow	2 x 50 gpm (2 x 189 L/min)
Pilot pump	One gear
Maximum rated flow	9.5 gpm (36 L/min)
Pressure setting	400 psi (2758 kPa) (28.1 kg/cm ²)
System operating pressure	
Implement circuits	4060 psi (28 000 kPa) (286 kg/cm ²)
Travel circuits	5220 psi (36 000 kPa) (366 kg/cm ²)
Swing circuits	3500 psi (24 000 kPa) (246 kg/cm ²)
Relief valve setting	
Implement circuits	4350 psi (30 000 kPa) (306 kg/cm ²)
Travel circuits	5315 psi (36 650 kPa) (374 kg/cm ²)
Swing circuits	3500 psi (24 000 kPa) (246 kg/cm ²)

Oil filtration

Two 4-micron spin-on full flow return filters with bypass
One 40-micron pilot oil filter
Oil cooler All brazed aluminum hydraulic oil cooler, mounted side by side with engine coolant radiator.
Hydraulic connections Flat-face O-ring type

Cylinders:	Bore	Rod Diameter	Stroke
Boom (2)	4.9 in. (125 mm)	3.4 in. (85 mm)	51.8 in. (1315 mm)
Arm (1)	5.3 in. (135 mm)	3.7 in. (95 mm)	63.7 in. (1617 mm)
Bucket (1)	4.7 in. (120 mm)	3.2 in. (80 mm)	41.5 in. (1055 mm)

Boom and bucket cylinders have built-in hydraulic cushions on the extension side only. The arm cylinder has a built-in hydraulic cushion at each end of the stroke. All cylinder rods are ground, heat treated, chrome-plated and polished.

Swing Mechanism:

Swing speed, adjustable 0-13 rpm; factory adjusted to 10 rpm
Swing 360 degrees; axial piston, high torque, hydraulic motor integral crossover reliefs and multiple planetary gearing.
Swing brake Hydraulically released, spring applied, multiple wet-disk.
Swing bearing Sealed single row ball with internal drive, induction hardened ring and pinion gears and 500-hour lubrication interval. Convenient in-cab fitting for swing bearing lubrication.

Undercarriage:

Propel system (one for each track) High-torque, axial-piston hydraulic motors with counterbalance valve and planetary drive are integrated and completely enclosed within the track shoe width. Wet multiple-disk brakes automatically release while propelling and apply when stationary. Independent drive to each track permits counterrotation.

Undercarriage and track frame Excavator track-type undercarriage with heavy-duty frame with track guide. Each track frame is a formed, reinforced U-channel. A reinforced undercarriage frame joins the track frame to the swing bearing mount. Narrow, wide and wide-long undercarriage frames are available.

Track rollers and idlers Nine rollers and one idler per track. Permanently lubricated rollers and idlers have metal-faced seals. Idlers have heavy-duty spring recoil mechanisms. Through-hardened steel slides support and guide upper track.

Track adjustment Hydraulic
Undercarriage length:
Standard 12 ft. 6 in. (3.81 m)
Optional long 13 ft. 8 in. (4.17 m)

Track Shoes (each side):

Standard 12 ft. 6 in. (3.81 m) undercarriage length . . . 47 shoes
Optional 13 ft. 8 in. (4.17 m) undercarriage length . . . 51 shoes

Track Shoes:	Width	Shoes	Ground Contact	Average Ground Pressure
Standard 12 ft. 6 in. (3.81 m) undercarriage length				
24 in. (600 mm)	Triple (standard)	semigrousers (39 587 cm ²)	6136 sq. in. (39 587 cm ²)	6.5 psi (44.6 kPa) (0.46 kg/cm ²)
30 in. (750 mm)	Triple (optional)	semigrousers (49 484 cm ²)	7670 sq. in. (49 484 cm ²)	5.3 psi (36.6 kPa) (0.37 kg/cm ²)
Optional 13 ft. 8 in. (4.17 m) undercarriage length				
24 in. (600 mm)	Triple (standard)	semigrousers (43 379 cm ²)	6724 sq. in. (43 379 cm ²)	5.99 psi (41.3 kPa) (0.42 kg/cm ²)
30 in. (750 mm)	Triple (optional)	semigrousers (54 224 cm ²)	8405 sq. in. (54 224 cm ²)	4.92 psi (33.9 kPa) (0.35 kg/cm ²)

Track shoes are through-hardened, rolled alloy

Cab:

Large, isolation-mounted, with sound-absorbing materials under floor, on ceiling and sidewalls. Tinted safety glass windows. Front window can be stored overhead. Side windows, door, and roof hatch open for ventilation. Centralized monitoring with audible alarm. Floor mat.

Seat:

Deluxe, fully cushioned, cloth covered, with adjustable backrest, headrest and padded fold-up armrests. Independent horizontal and vertical adjustments.

Controls:

All hydraulic functions are pilot controlled for precise metering and low operator effort. Two adjustable levers control swing, boom, arm, and bucket functions. Right and left pedals control forward, reverse and counterrotation movements. All pilot controls are neutralized by a lever on the left console.

Boom and Arm:

Internally reinforced tapered-box construction with heat-treated steel bushings. Pivot points are sealed to allow extended lubrication intervals. In critical joints, pivot pins are chrome-plated for extended service life. Machined and line-bored after welding for accurate alignment. Centralized lubrication system allows servicing from ground level.

Servicing and Vandal Protection:

Swingaway service doors expose built-in platforms and handrails. Hinged hood provides easy access to engine and hydraulic systems. Cab and service access areas lock with the common ignition switch key. Optional lockable vandal covers available to protect all cab windows.

Capacities:	U.S.	Liters
Fuel tank	70 gal.	265
Cooling system	31 qt.	29
Engine lubrication, including filter	20 qt.	19
Hydraulic system	96 gal.	363
Planetary propel drive (each)	6.0 qt.	5.7

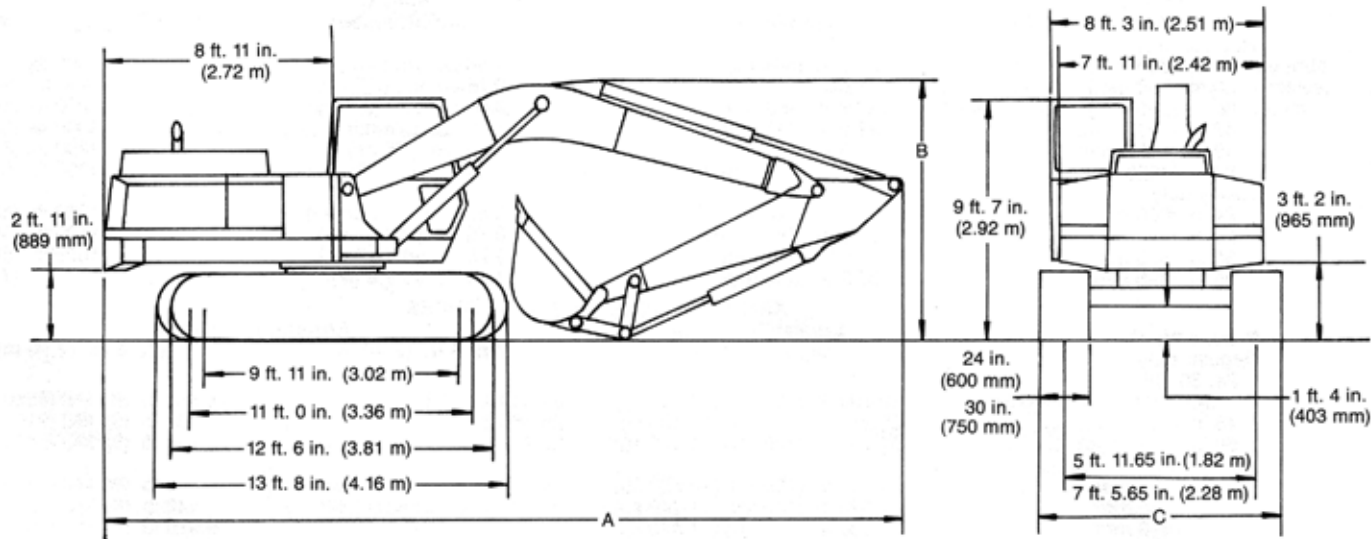

- A. With 7 ft. 3 in. (2.2 m) arm, 31 ft. 7 in. (9.62 m)
With 9 ft. 6 in. (2.9 m) arm, 31 ft. 2 in. (9.51 m)
- B. With 7 ft. 3 in. (2.2 m) arm, 8 ft. 11 in. (2.72 m)
With 9 ft. 6 in. (2.9 m) arm, 9 ft. 5 in. (2.87 m)

- C. With 5 ft. 11.65 in. (1.82 m) undercarriage and
24 in. (600 mm) narrow shoes: 7 ft. 11.28 in. (2.42 m)
30 in. (750 mm) wide shoes: 8 ft. 5.18 in. (2.57 m)
- With 7 ft. 5.65 in. (2.28 m) undercarriage and
24 in. (600 mm) narrow shoes: 9 ft. 5.39 in. (2.88 m)
30 in. (750 mm) wide shoes: 9 ft. 11.29 in. (3.03 m)

Weights:

Operating weight w/full fuel tank, 175-lb. (80 kg) operator, 42-in. (1067 mm) bucket, 9 ft. 6-in. (2.90 m) arm, 12 ft. 6-in. (3.81 m) undercarriage length, with 7 ft. 6-in. (2.29 m) wide gauge, 2200 lb. (1000 kg) auxiliary counterweight with:

24-in. (600 mm) triple grouser shoes	39,730	18 025
30-in. (750 mm) triple grouser shoes	40,690	18 455

Component -

Upperstructure (less front attachments and undercarriage)	15,360	6970
One-piece boom (with arm cylinder)	3,330	1510
Arm, 9 ft. 6 in. (2.90 m) w/bucket cylinder and linkage	2,020	910
Arm, 7 ft. 3 in. (2.20 m) w/bucket cylinder and linkage	1,860	845
Boom lift cylinders (2), total weight	800	360
Main counterweight	4280	1940
Optional auxiliary counterweights (one set)	1,100	500
Optional auxiliary counterweights (two sets)	2,200	1000

Undercarriage:		Triple Grouser Shoes	
Length	Gauge	24 in. (600 mm)	30 in. (750 mm)
12 ft. 6 in. (3.81 m)	6 ft. 0 in. (1.83 m)	14,310 lb. (6490 kg)	15,270 lb. (6925 kg)
12 ft. 6 in. (3.81 m)	7 ft. 6 in. (2.29 m)	14,720 lb. (6680 kg)	15,680 lb. (7110 kg)
13 ft. 8 in. (4.17 m)	7 ft. 6 in. (2.29 m)	15,300 lb. (6940 kg)	16,340 lb. (7410 kg)

Operating Information:

With 24-42 in. (600-1070 mm) regular duty buckets:

- Drawbar pull 36,000 lb. (160 kN)
- Tractive gradability 177% (60 deg.)
- Off-level operating limit for oil sumps 100% (45 deg.)
- Swing speed 0-10 rpm; adjustable to 13 rpm
- Travel speed 0-2.4 mph (0-3.86 km/h)

	ARM	
Arm length	7 ft. 3 in. (2.20 m)	9 ft. 6 in. (2.90 m)
Arm force	24,310 lb. (108 kN)	18,880 lb. (84 kN)
Lifting capacity over front or rear @ ground level	(11 030 kg)	(8560 kg)
20 ft. (6.1 m) reach	8310 lb. (3770 kg)	8310 lb. (3770 kg)
	*10,210 lb. (4630 kg)	*10,230 lb. (4640 kg)

*With optional 13 ft. 8 in. (4.17 m) undercarriage length

	ARM	
A Max. reach	7 ft. 3 in. (2.20 m)	9 ft. 6 in. (2.90 m)
A' Max. reach @ ground level	30 ft. 7 in. (9.32 m)	32 ft. 10 in. (10.0 m)
B Max. digging depth	30 ft. 0 in. (9.14 m)	32 ft. 3 in. (9.83 m)
B' Max. digging depth @ 8 ft. (2.44 m) flat bottom	19 ft. 6 in. (5.94 m)	21 ft. 10 in. (6.65 m)
C Max. cutting height	29 ft. 8 in. (9.04 m)	31 ft. 1 in. (9.47 m)
D Max dumping height	20 ft. 3 in. (6.17 m)	21 ft. 6 in. (6.55 m)
E Min. swing radius	12 ft. 2 in. (3.71 m)	12 ft. 0 in. (3.66 m)
F Max. vertical wall	15 ft. 10 in. (4.83 m)	17 ft. 1 in. (5.21 m)

Digging Depth and Reach

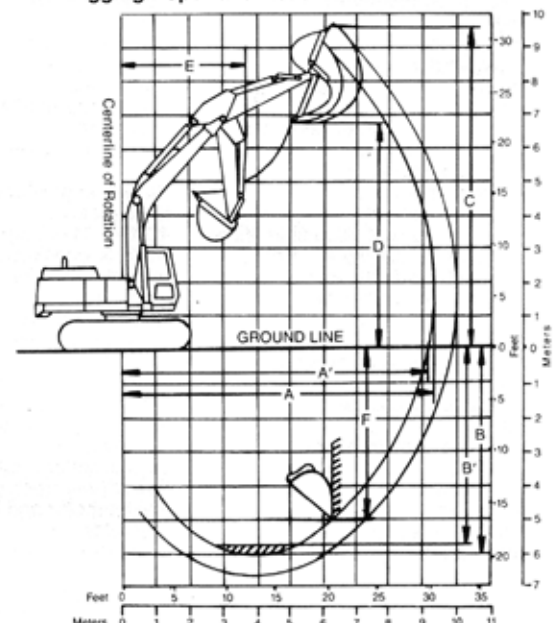

690D EXCAVATOR LIFTING CAPACITIES W/12 ft. 6 in. (3.81 m) UNDERCARRIAGE LENGTH

Ratings at bucket lift point, machine equipped with 7 ft. 6 in. (2.29 m) gauge undercarriage, 24 in. (600 mm) shoes, 42 in. (1067 mm) wide bucket, 2200 lb. (1000 kg) additional counterweight and situated on firm, uniform supporting surface. Total load includes weight of cables, hook, etc. **Boldface** type indicates hydraulic-limited capacities, lightface type indicates stability-limited capacities, in lb. (kg). Figures do not exceed 87 percent of hydraulic capacities or 75 percent of weight needed to tip machine.*

With 7 ft. 3 in. (2.20 m) ARM

LIFTING OVER FRONT OR REAR

Horizontal distance from centerline of rotation	10 ft. (3.05 m)	15 ft. (4.57 m)	20 ft. (6.10 m)	25 ft. (7.62 m)	30 ft. (9.14 m)
20 ft. (6.09 m)			8780 (3980)	6760 (3070)	
15 ft. (4.57 m)		10,970 (4970)	9420 (4270)	6490 (2940)	
10 ft. (3.05 m)		14,390 (6530)	9110 (4130)	6290 (2860)	
5 ft. (1.52 m)		13,450 (6100)	8610 (3910)	6080 (2760)	
Ground level		12,970 (5880)	8310 (3770)	5930 (2690)	
- 5 ft. (- 1.52 m)	14,030 (6370)	12,990 (5890)	8230 (3730)	5930 (2690)	
- 10 ft. (- 3.05 m)	21,610 (9800)	13,240 (6000)	8390 (3810)		
- 15 ft. (- 4.57 m)		12,090 (5480)			

LIFTING OVER SIDE OR 360 DEGREES

Horizontal distance from centerline of rotation:	10 ft. (3.05 m)	15 ft. (4.57 m)	20 ft. (6.10 m)	25 ft. (7.62 m)	30 ft. (9.14 m)
20 ft. (6.09 m)			7610 (3450)	5160 (2340)	
15 ft. (4.57 m)		10,970 (4970)	7340 (3330)	4900 (2220)	
10 ft. (3.05 m)		10,660 (4830)	6870 (3110)	4720 (2140)	
5 ft. (1.52 m)		9810 (4450)	6400 (2900)	4510 (2050)	
Ground level		9370 (4250)	6110 (2770)	4370 (1980)	
- 5 ft. (- 1.52 m)	14,030 (6370)	9390 (4260)	6040 (2740)	4370 (1980)	
- 10 ft. (- 3.05 m)	19,350 (8780)	9610 (4360)	6200 (2810)		
- 15 ft. (- 4.57 m)		10,160 (4610)			

With 9 ft. 6 in. (2.90 m) ARM

LIFTING OVER FRONT OR REAR

Horizontal distance from centerline of rotation:	10 ft. (3.05 m)	15 ft. (4.57 m)	20 ft. (6.10 m)	25 ft. (7.62 m)	30 ft. (9.14 m)
20 ft. (6.09 m)				5770 (2620)	
15 ft. (4.57 m)			8120 (3680)	6480 (2940)	4340 (1970)
10 ft. (3.05 m)	19,410 (8800)	12,590 (5710)	9210 (4180)	6260 (2840)	4500 (2040)
5 ft. (1.52 m)	8990 (4080)	13,750 (6230)	8690 (3940)	6010 (2730)	4380 (1990)
Ground level	7130 (3240)	13,130 (5960)	8310 (3770)	5810 (2640)	4320 (1960)
- 5 ft. (- 1.52 m)	13,860 (6290)	12,970 (5880)	8140 (3690)	5720 (2600)	
- 10 ft. (- 3.05 m)	25,000 (11 340)	13,070 (5930)	8170 (3710)	5840 (2650)	
- 15 ft. (- 4.57 m)	20,170 (9150)	13,440 (6100)	8480 (3850)		

LIFTING OVER SIDE OR 360 DEGREES

Horizontal distance from centerline of rotation:	10 ft. (3.05 m)	15 ft. (4.57 m)	20 ft. (6.10 m)	25 ft. (7.62 m)	30 ft. (9.14 m)
20 ft. (6.09 m)				5030 (2280)	
15 ft. (4.57 m)			7410 (3360)	4880 (2210)	3440 (1560)
10 ft. (3.05 m)	19,410 (8800)	11,120 (5040)	6950 (3150)	4680 (2120)	3290 (1490)
5 ft. (1.52 m)	8990 (4080)	10,060 (4560)	6470 (2930)	4440 (2020)	3170 (1440)
Ground level	7130 (3240)	9500 (4310)	6110 (2770)	4250 (1930)	3120 (1410)
- 5 ft. (- 1.52 m)	13,860 (6290)	9350 (4240)	5950 (2700)	4160 (1890)	
- 10 ft. (- 3.05 m)	19,060 (8650)	9450 (4290)	5980 (2710)	4280 (1940)	
- 15 ft. (- 4.57 m)	19,650 (8910)	9780 (4440)	6270 (2840)		

* Stability-limited capacities are decreased 8 percent if additional counterweight is reduced to 1100 lb. (500 kg) and 16 percent if machine is equipped with no additional counterweight.

Stability-limited, over-side lift capacities are decreased 26 percent if machine is equipped with 6 ft. (1.83 m) gauge undercarriage.

690D EXCAVATOR LIFTING CAPACITIES W/13 ft. 8 in. (4.17 m) UNDERCARRIAGE LENGTH

Ratings at bucket lift point, machine equipped with 7 ft. 6 in. (2.29 m) gauge undercarriage, 30 in. (750 mm) shoes, 42 in. (1067 mm) wide bucket, 2200 lb. (1000 kg) additional counterweight and situated on firm, uniform supporting surface. Total load includes weight of cables, hook, etc. **Boldface** type indicates hydraulic-limited capacities, lightface type indicates stability-limited capacities, in lb. (kg). Figures do not exceed 87 percent of hydraulic capacities or 75 percent of weight needed to tip machine.*

With 7 ft. 3 in. (2.20 m) ARM

LIFTING OVER FRONT OR REAR

Horizontal distance from centerline of rotation:	10 ft. (3.05 m)	15 ft. (4.57 m)	20 ft. (6.10 m)	25 ft. (7.62 m)	30 ft. (9.14 m)
20 ft. (6.09 m)			9380 (4260)	8130 (3690)	
15 ft. (4.57 m)		11,700 (5310)	10,070 (4570)	7850 (3560)	
10 ft. (3.05 m)		15,550 (7050)	11,050 (5010)	7660 (3470)	
5 ft. (1.52 m)		16,670 (7560)	10,530 (4780)	7430 (3370)	
Ground level		16,160 (7330)	10,210 (4630)	7280 (3300)	
- 5 ft. (- 1.52 m)	14,820 (6720)	16,180 (7340)	10,130 (4600)	7280 (3300)	
- 10 ft. (- 3.05 m)	23,080 (10 470)	16,440 (7460)	10,300 (4670)		
- 15 ft. (- 4.57 m)		12,960 (5880)			

LIFTING OVER SIDE OR 360 DEGREES

Horizontal distance from centerline of rotation:	10 ft. (3.05 m)	15 ft. (4.57 m)	20 ft. (6.10 m)	25 ft. (7.62 m)	30 ft. (9.14 m)
20 ft. (6.09 m)			7910 (3590)	5390 (2440)	
15 ft. (4.57 m)		12,300 (5580)	7640 (3470)	5130 (2330)	
10 ft. (3.05 m)		11,100 (5030)	7170 (3250)	4950 (2240)	
5 ft. (1.52 m)		10,250 (4650)	6700 (3040)	4740 (2150)	
Ground level		9810 (4450)	6410 (2910)	4590 (2080)	
- 5 ft. (- 1.52 m)	14,820 (6720)	9820 (4460)	6340 (2880)	4600 (2090)	
- 10 ft. (- 3.05 m)	20,150 (9140)	10,050 (4560)	6500 (2950)		
- 15 ft. (- 4.57 m)		10,600 (4810)			

With 9 ft. 6 in. (2.90 m) ARM

LIFTING OVER FRONT OR REAR

Horizontal distance from centerline of rotation:	10 ft. (3.05 m)	15 ft. (4.57 m)	20 ft. (6.10 m)	25 ft. (7.62 m)	30 ft. (9.14 m)
20 ft. (6.09 m)				6160 (2790)	
15 ft. (4.57 m)			8710 (3950)	7840 (3560)	4660 (2110)
10 ft. (3.05 m)	20,660 (9370)	13,440 (6100)	10,430 (4730)	7630 (3460)	5000 (2270)
5 ft. (1.52 m)	9550 (4330)	16,990 (7710)	10,620 (4820)	7370 (3340)	5420 (2460)
Ground level	7610 (3450)	16,330 (7410)	10,230 (4640)	7160 (3250)	5360 (2430)
- 5 ft. (- 1.52 m)	14,700 (6670)	16,160 (7330)	10,040 (4560)	7070 (3210)	
- 10 ft. (- 3.05 m)	27,190 (12 330)	16,270 (7380)	10,080 (4570)	7190 (3260)	
- 15 ft. (- 4.57 m)	21,560 (9780)	15,650 (7100)	10,400 (4720)		

LIFTING OVER SIDE OR 360 DEGREES

Horizontal distance from centerline of rotation:	10 ft. (3.05 m)	15 ft. (4.57 m)	20 ft. (6.10 m)	25 ft. (7.62 m)	30 ft. (9.14 m)
20 ft. (6.09 m)				5260 (2380)	
15 ft. (4.57 m)			7710 (3500)	5110 (2320)	3630 (1650)
10 ft. (3.05 m)	20,660 (9370)	11,550 (5240)	7250 (3290)	4910 (2230)	3480 (1580)
5 ft. (1.52 m)	9550 (4330)	10,500 (4760)	6770 (3070)	4670 (2120)	3360 (1520)
Ground level	7610 (3450)	9940 (4510)	6410 (2910)	4480 (2030)	3300 (1500)
- 5 ft. (- 1.52 m)	14,700 (6670)	9790 (4440)	6250 (2830)	4390 (1990)	
- 10 ft. (- 3.05 m)	19,860 (9010)	9890 (4480)	6280 (2850)	4510 (2040)	
- 15 ft. (- 4.57 m)	20,450 (9280)	10,220 (4640)	6570 (2980)		

*Stability-limited capacities are decreased 8 percent if additional counterweight is reduced to 1100 lb. (500 kg) and 16 percent if machine is equipped with no additional counterweight.

690D EXCAVATOR BUCKETS

Buckets: High-strength steel, ribbed and double-plated bottom section, lift loop

Nominal	Bite Width	Capacity SAE (Heaped)	Weight
Regular duty			
24 in. (600 mm)	25.5 in. (648 mm)	0.56 cu. yd. (.43 m ³)	1000 lb. (455 kg)
30 in. (750 mm)	31.5 in. (800 mm)	0.75 cu. yd. (.57 m ³)	1100 lb. (500 kg)
36 in. (900 mm)	37.5 in. (953 mm)	0.88 cu. yd. (.67 m ³)	1200 lb. (545 kg)
42 in. (1067 mm)	43.5 in. (1105 mm)	1 cu. yd. (.76 m ³)	1300 lb. (590 kg)
48 in. (1220 mm)	49.5 in. (1257 mm)	1 cu. yd. (.76 m ³)	1200 lb. (545 kg)
60 in. (1520 mm)	60.0 in. (1524 mm)	1.38 cu. yd. (1.05 m ³)	1200 lb. (545 kg)
Heavy duty			
24 in. (600 mm)	26.0 in. (660 mm)	0.625 cu. yd. (.48 m ³)	1380 lb. (625 kg)
29 in. (740 mm)	31.0 in. (787 mm)	0.75 cu. yd. (.57 m ³)	1500 lb. (680 kg)
35 in. (890 mm)	37.0 in. (940 mm)	0.75 cu. yd. (.57 m ³)	1525 lb. (690 kg)
35 in. (890 mm)	37.0 in. (940 mm)	1.00 cu. yd. (.8 m ³)	1574 lb. (714 kg)

ARM AND BUCKET DIGGING FORCES

Bucket Width Regular duty	Bucket Tangential Digging Forces	Arm Digging Forces	
		7 ft. 3 in. (2.20 m)	9 ft. 6 in. (2.90 m)
24, 30, 36, 42 in. (600, 750, 900, 1070 mm)	22,790 lb. (101 kN) (10 340 kg)	24,310 lb. (108 kN) (11 030 kg)	18,880 lb. (84 kN) (8560 kg)
48 in. (1220 mm)	28,210 lb. (125 kN) (12 800 kg)	26,360 lb. (117 kN) (11 960 kg)	20,190 lb. (90 kN) (9160 kg)
60 in. (1520 mm)	31,250 lb. (139 kN) (14 170 kg)	27,207 lb. (121 kN) (12 340 kg)	20,730 lb. (92 kN) (9400 kg)
Heavy duty			
24 in. (600 mm)	23,550 lb. (105 kN) (10 680 kg)	24,750 lb. (110 kN) (11 230 kg)	19,170 lb. (85 kN) (8700 kg)
29 in. (740 mm)	24,570 lb. (109 kN) (11 140 kg)	25,170 lb. (112 kN) (11 420 kg)	19,440 lb. (86 kN) (8820 kg)
35 in. (890 mm)	26,330 lb. (117 kN) (11 940 kg)	25,920 lb. (115 kN) (11 760 kg)	19,920 lb. (89 kN) (9040 kg)
35 in. (890 mm)	23,550 lb. (105 kN) (10 680 kg)	24,750 lb. (110 kN) (11 230 kg)	19,170 lb. (85 kN) (8700 kg)

BUCKET SELECTION CHART Recommended Bucket Size*

lb/yd ³	kg/m ³	MATERIAL	Regular Duty		Heavy Duty	
			cu. yd.	(m ³)	cu. yd.	(m ³)
700	420	Wood chips	5.0	3.8	—	—
800	470	Peat, dry	4.5	3.4	—	—
1250	740	Peat, wet	3.0	2.3	—	—
1450	860	Cinders	2.5	1.9	—	—
1600	950	Topsoil, loose	2.0	1.5	—	—
2300	1360	Topsoil, heavy packed	1.75	1.34	—	—
2300	1360	Coal, natural bed	1.75	1.34	—	—
2600	1540	Earth, dry loam	1.38	1.06	—	—
2700	1600	Sand, dry	1.38	1.06	1.00	.76
3200	1900	Earth, moist loam	1.12	.86	.88	.67
3250	1930	Sand, gravel, dry	1.12	.86	.88	.67
3300	1960	Sand, moist	1.12	.86	.88	.67
3500	2080	Sand, wet	1.00	.76	.75	.57
3500	2080	Shale	1.00	.76	.75	.57
3600	2100	Clay, wet	.88	.67	.62	.47
4200	2490	Limestone, broken	—	—	.62	.47
4600	2730	Rock, granite, blasted	—	—	.62	.47

*Contact your John Deere dealer for optimum bucket and attachment selection. The use of larger than recommended buckets in heavy materials and tough conditions should be carefully analyzed for digging force and load capacity. Bucket capacity indicated is SAE heaped.

Additional Standard Equipment:

- Cab:**
 - Adjustable lever pilot controllers
 - Heater, 20,000 Btu/hr (5.9 kW)
 - Horn
 - Interior light
 - Positive position hand throttle w/fuel economy position
 - Tinted glass
 - Travel alarm w/cancel switch
 - Front windshield wiper
 - Monitor system with alarm features—
 - Engine air cleaner restriction indicator light
 - Engine alternator charge indicator light
 - Engine coolant temperature warning light w/audible alarm
 - Engine oil pressure warning light w/audible alarm
 - Hydraulic oil filter restriction indicator light
 - Hydraulic oil temperature indicator w/audible alarm
 - Work lights—on indicator
 - Auto-idle indicator
 - Gauges:
 - Engine coolant gauge
 - Fuel gauge
 - Hourmeter
 - Digital clock
 - Instrument lights
 - Literature storage compartment
- Engine:**
 - Antifreeze
 - Auto-idle system
 - Dual dry-type air filter
 - Electric fuel shut off
 - Fan guard
 - Heavy-duty fuel filter
 - Full-flow oil filter
 - Isolation-mounted engine
 - Heavy-duty low maintenance batteries
 - Underhood muffler w/vertical exhaust
 - Viscous fan drive
- Frame:**
 - Hinged engine cover
 - Built-in service platforms
 - 4280-lb. (1940 kg) counterweight
 - Toolbox w/lockable cover
 - Vandal protection—locking service doors
- Front attachments:**
 - Bucket clearance adjusting mechanism
 - Centralized lubrication system
 - Dirt seals on all bucket pins
 - 9 ft. 6 in. (2.9 m) standard arm
- Undercarriage:**
 - Center bottom guard
 - Lower front track guide
 - Propel motor and hydraulic line shields
 - 24-in. (600 mm) triple grouser shoes
 - Track length 12 ft. 6 in. (3.81 m)
 - Tow loops, front and rear
 - Upper track slides

Optional or Special Equipment:

- Cab:**
 - Air conditioner w/integral heater
 - Air conditioner, 20,000 Btu/hr (5.9 kW)
 - Heater, 40,000 Btu/hr (11.7 kW)
 - Heater, 40,000 Btu/hr (11.7 kW)
 - Alternate pilot control pattern
 - Hand lever travel controls
 - Rearview mirrors
 - Seat belt
 - Window protection covers
- Engine:**
 - Engine coolant heater
 - Electric cold weather (ether) starting aid
 - Heavy-duty four-battery system with 360 minutes reserve capacity recommended for cold weather starting below -15°F (-26°C)
- Frame:**
 - Auxiliary counterweight system,
 - 1100 lb. (500 kg) (one set)
 - 2200 lb. (1000 kg) (two sets)
- Front attachments:**
 - 7 ft. 3 in. (2.20 m) arm
 - Heavy-duty buckets with side cutters and teeth
 - Halogen work lights—two boom mounted
 - Ripper tooth
 - No-boom-arm-bucket option
- Hydraulic system:**
 - Auxiliary hydraulic control valves w/flow adjustment
 - Auxiliary pilot and electric controls
 - Auxiliary boom and arm hydraulic lines
- Undercarriage:**
 - 30-in. (750 mm) triple semigrouser shoes
 - 12 ft. 6 in. (3.81 m) undercarriage length,
 - 6 ft. 0 in. (1.83 m) gauge
 - 13 ft. 8 in. (4.17 m) undercarriage length,
 - 7 ft. 6 in. (2.29 m) gauge
 - No-undercarriage option