



D

EXCAVATORS

190D W | 220D W



WHEELED



Get on a roll.

If you're looking to roll in more productivity, roll up to the jobsite in a new set of wheels. The bigger, stronger 190D W and 220D W Wheeled Excavators travel on tires, so they're more mobile and maneuverable than truck-mounted and tracked excavators. Both models feature heavy-duty fuel-efficient engines, along with a host of other productivity and uptime-boosting

enhancements. Like a highly efficient cooling system. And a best-in-class cab with more leg-room, noticeably lower noise levels, and an easy-to-use multifunction monitor. Delivering the power, smoothness, ease of operation, and comfort you'd expect from Deere, these excavators have everything you need to get more done for less.



Fuel-efficient, EPA Tier 3/EU Stage IIIA engines deliver power without compromise in all conditions.

The best-in-class cab has substantially more legroom, noticeably lower noise levels, and ergonomic low-effort controls.

Powerwise III™ engine/hydraulic management system maximizes power output and delivers smooth multifunction operation on less fuel.

Extended engine and hydraulic fluid service intervals increase uptime and reduce daily operating costs.

Choose from a variety of boom, blade, outrigger, and bucket options to equip your machine exactly as needed to optimize your setup.

Shift on the go. Two-speed PowerShift™ transmission ensures a smooth shift every time, protecting the drivetrain — and operator — from sudden downshifts.

The D-Series' short wheelbase makes them very adept in close quarters — unlike unwieldy truck-mounted excavators. For work close-up, opt for the two-piece boom.

Rubber tires allow you to drive quickly from job to job instead of loading up a trailer — plus they're much more friendly to paved surfaces.

Specifications	190D W	220D W
SAE Net Power	119 kW (159 hp)	119 kW (159 hp)
Operating Weight	20 700 kg (45,636 lb.)*	23 588 kg (52,003 lb.)*
Digging Depth	5.93 m (19 ft. 5 in.)	6.08 m (19 ft. 11 in.)
Arm Force	82.3 kN (18,509 lb.)	101.7 kN (22,873 lb.)
Bucket Force	101.9 kN (22,916 lb.)	128.6 kN (28,904 lb.)

* With two-piece boom and front and rear outriggers.

On the 220D W, wider axles and more weight provide more stability and lift capability, so you can quickly move Jersey barriers.

Faster travel speed and boom and arm movement combined with superior arm force help speed cycle times.

Noise levels — and consequently, operator fatigue — have been significantly reduced. High-efficiency cooling fan, noise-suppression muffler, and isochronous high-idle speed help keep things quiet.

Powerwise III™ management system perfectly balances engine performance and hydraulic flow for fast, smooth, predictable operation. One work mode makes it easy to be productive in any application.

Standard deluxe lighting package provides 360-degree illumination of the work area so you can extend the workday beyond daylight hours.

If you don't need a blade, choose the four-outrigger option for maximum stability. You can activate the outriggers together or independently to quickly and easily level the machine.

Low-flow, assist hydraulics come standard, perfect for lower-pressure, lower-flow applications like bucket-tilt or bucket-swinger attachments.

Need additional hydraulic capability? Dealer-installed high-pressure, high-flow auxiliary hydraulic packages are available.

Joystick controllers are pre-fitted for auxiliary controls, so it's easy and inexpensive to add auxiliary hydraulics.

Changing hydraulic flow is pushbutton easy using the monitor. Accommodates a variety of attachment needs, right from the seat.

1. Mono boom delivers the reach and lift capacity you need for long-distance work. Or opt for a two-piece boom for added versatility.
2. Cooled exhaust gas recirculation (EGR), four-valve-per-cylinder head, and high-pressure common-rail fuel system enable the 5.2-L engines to meet EPA Tier 3/EU Stage IIIA emissions standards without sacrificing power or fuel efficiency.
3. Significant increases in horsepower, weight, and dig forces make these machines highly productive for a wide variety of work.
4. Refined parallelogram blade better handles backfill and cleanup duties, while serving as a third stabilizer during digging.





Easy street.

Street work has never been easier than with John Deere wheeled excavators. With strong digging forces and superior lift capacity and reach, they're perfect for a variety of work, whether it's clearing ditches, repairing sewers, or moving Jersey barriers. Rubber tires and transport speeds as fast as 35 km/h (21.7 mph) mean you don't

need to load them on a trailer to travel a stone's throw away or across pavement. Plenty of street smarts, too, with the Powerwise III™ engine/hydraulic management system delivering pinpoint metering for smooth, predictable control. Add any of the many available options to tackle a wide variety of on- and off-road work.

A high-angle, close-up photograph of the operator's cab interior of a D-Series Wheeled Excavator. The view is from the driver's perspective, looking towards the front. The steering wheel is prominent in the foreground, with a black grip and a central hub. To the right of the wheel is a large, black, ergonomic joystick control. The dashboard and control panel are visible, featuring various buttons, switches, and a digital display. The interior is finished with grey plastic and fabric seats. A yellow accent is visible on the side panel. The overall lighting is bright, highlighting the textures and components of the cab.

Get the most out of every shift.

If you want your operators to really shift into high gear, put them behind the controls of a D-Series Wheeled Excavator. Its spacious, well-appointed interior provides everything needed for maximum productivity. Ergonomic low-effort controls. Intuitive multifunction monitor. A wider expanse of tinted glass for virtually unrestricted visibility. Substantially more legroom

and ample storage space for cups, coolers, and other carryons. More peace and quiet, too, with a sound-suppressed cab that noticeably reduces fatigue-causing noise. And plenty of creature comforts including an AM/FM radio, automatic high-capacity climate-control system, and a convenient 12-volt port. For more productivity, shift after shift.



Deluxe-suspension multi-position seat slides together or independently of the control console, so it won't cramp an operator's style.

Steering wheel is infinitely adjustable for more comfortable operation. Tilts up and out of the way for easy entry and exit.

Two-speed PowerShift™ transmission shifts smoothly on-the-go from low to high. Downshifting isn't a problem either, since the transmission will only shift within certain travel-speed parameters — protecting both operator and drivetrain.

Generous hydraulic flow and best-in-class metering ensure powerful digging force, precise low-effort control, and superb multifunction operation. Quick, responsive pump activation eliminates any delay in functions.

Roomy cab is noticeably quiet and comfortable. Silicone-filled mounts effectively isolate operators from noise and vibration.

A wider expanse of right-hand window glass combined with narrower front cab posts and front steering console provide virtually unobstructed all-around visibility. Even the overhead tinted hatch is larger, making it easier to see obstacles overhead.

Ergonomic short-throw pilot levers provide smooth, predictable fingertip control with less effort.

1. The F-N-R directional switch is now more conveniently located on the underside of the right-hand pilot lever. Push buttons on the right lever allow fingertip control of auxiliary hydraulic flow for operating attachments.
2. Automatic, high-velocity bi-level climate-control system with automotive-style louvers keep the view clear and the cab comfortable.
3. No shortage of storage space in here, including a place for a lunch box, cup holders, and even a hot/cold box that keeps refreshments at just the right temperature.
4. Intuitive, multi-language LCD monitor provides a wealth of information and control, including pump-flow adjustment, maintenance tracking, onboard diagnostics, and service monitoring.



Heavy-duty covers on the oversize outriggers help prevent damage to the hydraulic cylinders.

Heavy-duty diesel engines start easy, run quiet, and are easy on fuel.

Welded bulkheads within the boom resist torsional stress for long-term durability. Rigid, reinforced D-channel side frames resist impact, providing maximum cab and component protection.

Powdered metal oil-impregnated bushings enhance durability and extend grease intervals to 500 hours for the arm-and-boom joint and 100 hours for the bucket joint. Reinforced resin thrust plates increase lube intervals to 500 hours.

Larger chassis beams, swing bearings, and boom foot areas (220D W) deliver rock-solid durability.

New cooling system keeps the engine and hydraulics cool in the toughest environments.



1

1. Wet-type disc brakes are virtually maintenance free and deliver reliable, long-term stopping power.



2

2. Tungsten-carbide coating creates an extremely wear-resistant surface to protect the all-important bucket-to-arm joint.

3. Standard solid-rubber spacer between the heavy-duty dual tires keeps mud and debris out for longer tire life.

4. PowerShift™ transmission has been integrated with the axle and repositioned higher above ground to better protect it from damage.



3



4



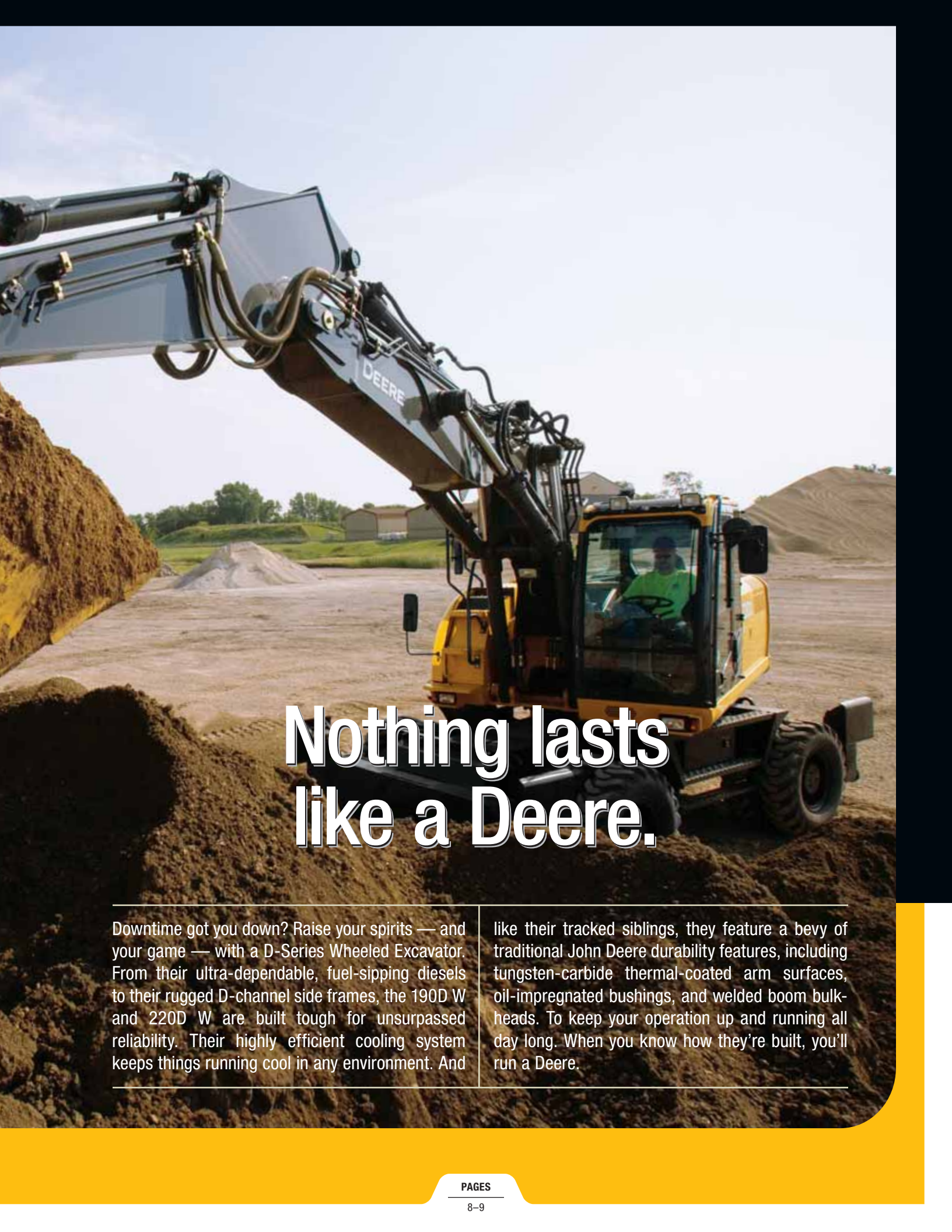

Nothing lasts like a Deere.

Downtime got you down? Raise your spirits — and your game — with a D-Series Wheeled Excavator. From their ultra-dependable, fuel-sipping diesels to their rugged D-channel side frames, the 190D W and 220D W are built tough for unsurpassed reliability. Their highly efficient cooling system keeps things running cool in any environment. And

like their tracked siblings, they feature a bevy of traditional John Deere durability features, including tungsten-carbide thermal-coated arm surfaces, oil-impregnated bushings, and welded boom bulkheads. To keep your operation up and running all day long. When you know how they're built, you'll run a Deere.

Machine Information Center (MIC) captures and stores vital machine performance and utilization data to help improve uptime, productivity, and profit.

Auto-idle automatically reduces engine speed when hydraulics aren't in use. Reduces noise and preserves precious fuel.

500-hour engine and 5,000-hour hydraulic oil-service intervals enable these machines to work longer between stops for scheduled service.

Lube banks, filters, and checkpoints are grouped for quick and convenient access.

Centralized lube banks place difficult-to-lube zerks within easy reach, for faster greasing with less mess.

Nobody backs you better than the 500-plus John Deere dealers throughout North America.



Get a better handle on daily operating costs.

If you're trying to hold down daily operating costs, get your hands on a John Deere excavator. Large service doors provide wide-open access to daily checkpoints. Easy-access, remote-mount oil and fuel filters can be changed without crawling under the machine or removing access panels, reducing

service time. And extended service intervals let you work longer between changes. Plus the Machine Information Center and state-of-the-art monitor with onboard diagnostics help you make timely decisions about machine upkeep — and maximize uptime, productivity, and profits.

1. Ground-level fresh-air cab filter is quickly serviced from outside the cab. Where it's more likely to get done.

2. Easy-to-navigate LCD color monitor provides maintenance alerts and diagnostic messages to help defeat downtime.

3. Large, wide-open service doors provide quick and easy access to daily service items.

4. Vertical spin-on engine oil filters and fuel/water separators are conveniently grouped in the right rear compartment for easy, ground-level servicing.

5. Reinforced resin thrust plates, grooved bushings, and thermal-coated bucket joints increase arm, boom, and bucket lube intervals to 500 hours.

6. Fuel coolers and A/C condensers swing out, simplifying clean out. Side-by-side coolers provide easy access.



Specifications

190D
W

Engine	190D W
Manufacturer and Model	Isuzu 4HK1X
Non-Road Emissions Standard	EPA Tier 3/EU Stage IIIA
Cylinders	4
Displacement	5.2 L (317 cu. in.)
SAE Net Rated Power @ 2,000 rpm	119 kW (159 hp)
Off-Level Capacity	67%
Aspiration	turbocharged and intercooled

Cooling
Direct-drive, suction-type fan

Powertrain	
Two-speed propel with creeper mode and automatic shift	
Travel Speed (maximum)	
Creeper	2.6 km/h (1.6 mph)
Low	8.5 km/h (5.3 mph)
High	35.0 km/h (21.7 mph)
Front Axle	all-wheel drive; can be locked hydraulically in any position
Oscillation	±7 deg.

Brakes maintenance-free wet-disc brakes on front and rear axles; fully hydraulic service brakes

Hydraulics	
Auxiliary hydraulic flow adjustable through monitor	
Main Pumps	2 variable-displacement axial-piston pumps
Pump Flow (maximum x 2)	189 L/m (49.9 gpm)
Pilot Pump	one gear
Maximum Rated Flow	27.7 L/m (7.3 gpm)
System Relief Pressure	3900 kPa (566 psi)
System Operating Pressure	
Implement Circuits	34 300 kPa (4,975 psi)
Travel Circuits	34 300 kPa (4,975 psi)
Swing Circuits	32 400 kPa (4,699 psi)
Controls	pilot levers, short stroke, low effort; hydraulic pilot controls with shutoff lever

Cylinders	Heat-treated, chrome-plated, polished cylinder rods, hardened steel (replaceable bushings) pivot pins		
	Bore	Rod Diameter	Stroke
Monoblock Boom (2)	120 mm (4.7 in.)	85 mm (3.3 in.)	1050 mm (41.3 in.)
2-Piece Boom (2)	120 mm (4.7 in.)	85 mm (3.3 in.)	980 mm (38.6 in.)
Positioning (2), 2-Piece Boom	170 mm (6.7 in.)	110 mm (4.3 in.)	670 mm (26.4 in.)
Arm (1)	125 mm (4.9 in.)	90 mm (3.5 in.)	1371 mm (54.0 in.)
Bucket (1)	105 mm (4.1 in.)	75 mm (3.0 in.)	1060 mm (41.7 in.)

Electrical	
Voltage	24 volt
Number of Batteries (12 volt)	2
Alternator Rating	50 amp
Lights (6)	headlights (2), top of cab (2), rear of cab (1), and boom (1)
Driving Lights	headlights (2), turn signals and hazard lights, brake lights, and side-marker lights

Upperstructure/Swing Mechanism	
Swing Speed	12.2 rpm
Swing Torque	40 403 Nm (29,800 lb.-ft.)

Serviceability

190D W

Refill Capacities

Fuel Tank	290 L (77 gal.)
Cooling System	22 L (6 gal.)
Engine Oil with Filter	23 L (6 gal.)
Hydraulic Tank	170 L (45 gal.)
Hydraulic System	240 L (63 gal.)
Swing Drive	6.9 L (7.3 qt.)
Transmission Pump	0.95 L (1 qt.)
Transmission	2.8 L (3 qt.)
Axle	
Front	9.5 L (2.5 gal.)
Rear	14 L (3.7 gal.)
Front and Rear Hubs	2 x 2.5 L (2 x 2.6 qt.)

Operating Weights

With Full Fuel Tank; 79-kg (175 lb.) Operator;

0.7-m³ (0.92 cu. yd.), 900-mm (35 in.),

610-kg (1,345 lb.) General-Purpose Bucket;

2.71-m (8 ft. 11 in.) Arm; Standard Gauge;

and 4200-kg (8,929 lb.) Counterweight

Monoblock Boom

Front and Rear Outrigger 19 971 kg (44,029 lb.)

Front Blade and Rear Outrigger 19 600 kg (43,211 lb.)

2-Piece Boom

20 700 kg (45,636 lb.)

20 400 kg (44,974 lb.)

Operating Dimensions

	Monoblock Boom
Arm Force	82.1 kN (18,465 lb.)
Bucket Digging Force	101.9 kN (22,916 lb.)
Lifting Capacity Over Front at Ground Level	
6.1-m (20 ft.) Reach	6152 kg (13,563 lb.)
A Maximum Reach	9.58 m (31 ft. 5 in.)
A' Maximum Reach at Ground Level	9.40 m (30 ft. 10 in.)
B Maximum Digging Depth	5.83 m (19 ft. 2 in.)
B' Maximum Digging Depth at 2.44-m (8 ft.) Flat Bottom	5.64 m (18 ft. 6 in.)
C Maximum Cutting Height	9.25 m (30 ft. 4 in.)
D Maximum Dumping Height	6.45 m (21 ft. 2 in.)
E Minimum Swing Radius	3.48 m (11 ft. 5 in.)
F Maximum Vertical Wall	5.26 m (17 ft. 3 in.)
G Tail Swing Radius	2.32 m (7 ft. 7 in.)

	2-Piece Boom
Arm Force	82.3 kN (18,509 lb.)
Bucket Digging Force	101.9 kN (22,916 lb.)
Lifting Capacity Over Front at Ground Level	
6.1-m (20 ft.) Reach	5760 kg (12,699 lb.)
A Maximum Reach	9.48 m (31 ft. 1 in.)
A' Maximum Reach at Ground Level	9.30 m (30 ft. 6 in.)
B Maximum Digging Depth	5.93 m (19 ft. 5 in.)
B' Maximum Digging Depth at 2.44-m (8 ft.) Flat Bottom	5.74 m (18 ft. 10 in.)
C Maximum Cutting Height	9.85 m (32 ft. 4 in.)
D Maximum Dumping Height	6.95 m (22 ft. 10 in.)
E Minimum Swing Radius	3.00 m (9 ft. 10 in.)
F Maximum Vertical Wall	5.26 m (17 ft. 3 in.)
G Tail Swing Radius	2.32 m (7 ft. 7 in.)

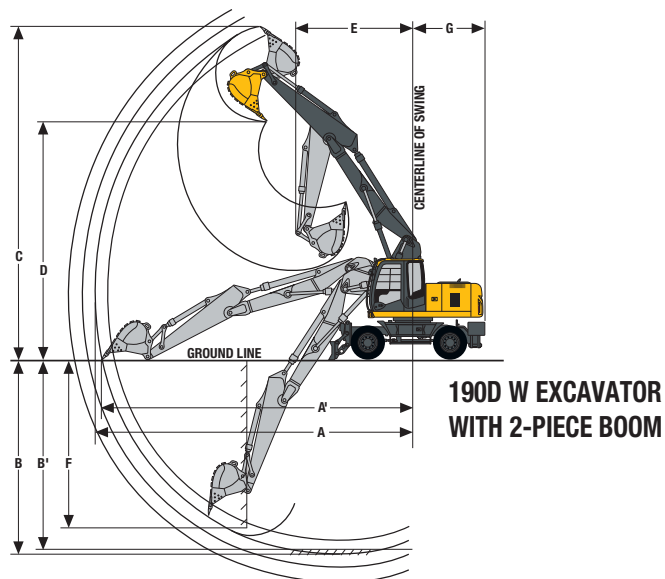
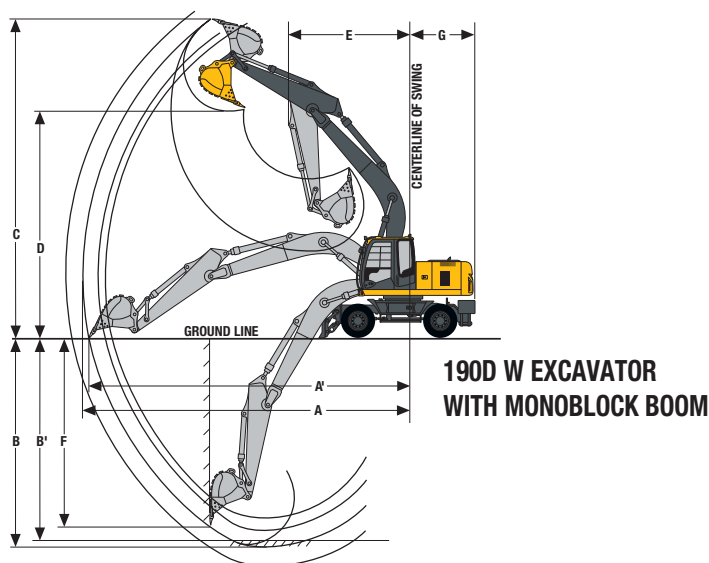

Machine Dimensions

190D W

With standard gauge. Dimensions are provided for both the front and rear outrigger configuration, and for the front blade and rear outrigger configuration.

Monoblock Boom

2-Piece Boom

A Overall Length (with 2.71-m [8 ft. 11 in.] arm)	8.98 m (29 ft. 6 in.)	
A' Overall Length (with 2.71-m [8 ft. 11 in.] arm)	8.80 m (28 ft. 10 in.)	
B Overall Height of Boom (with 2.71-m [8 ft. 11 in.] arm)	3.13 m (10 ft. 3 in.)	
B' Overall Height of Boom (with 2.71-m [8 ft. 11 in.] arm)	3.21 m (10 ft. 6 in.)	
C Rear-End Swing Radius	2.32 m (7 ft. 7 in.)	2.32 m (7 ft. 7 in.)
D Engine Cover Height	2.35 m (7 ft. 8 in.)	2.35 m (7 ft. 8 in.)
E Counterweight Clearance	1.24 m (4 ft. 1 in.)	1.24 m (4 ft. 1 in.)
F Overall Width of Upperstructure	2.45 m (8 ft. 0 in.)	2.45 m (8 ft. 0 in.)
G Overall Height of Cab	3.13 m (10 ft. 3 in.)	3.13 m (10 ft. 3 in.)
H Overall Width of Tires	2.53 m (8 ft. 4 in.)	2.53 m (8 ft. 4 in.)
J Minimum Ground Clearance	0.35 m (14 in.)	0.35 m (14 in.)
K Wheelbase	2.65 m (8 ft. 8 in.)	2.65 m (8 ft. 8 in.)
L Swing Center to Rear Axle	1.15 m (3 ft. 9 in.)	1.15 m (3 ft. 9 in.)
M Front Overhang		
Front and Rear Outrigger	1.38 m (4 ft. 6 in.)	1.38 m (4 ft. 6 in.)
Front Blade and Rear Outrigger	1.32 m (4 ft. 4 in.)	1.32 m (4 ft. 4 in.)
N Rear Overhang	1.09 m (3 ft. 7 in.)	1.09 m (3 ft. 7 in.)
O Maximum Blade Lower	0.22 m (9 in.)	0.22 m (9 in.)
P Overall Height of Blade	0.59 m (23 in.)	0.59 m (23 in.)
Q Maximum Blade Raise	0.37 m (15 in.)	0.37 m (15 in.)
R Overall Width of Blade	2.53 m (8 ft. 4 in.)	2.53 m (8 ft. 4 in.)
S Overall Width with Outrigger Retracted	2.47 m (8 ft. 1 in.)	2.47 m (8 ft. 1 in.)
T Overall Width with Outrigger Extended	3.44 m (11 ft. 3 in.)	3.44 m (11 ft. 3 in.)
V Overall Height of Boom (traveling, with 2.71-m [8 ft. 11 in.] arm)	3.97 m (13 ft. 0 in.)	3.97 m (13 ft. 0 in.)
W Front Overhang (traveling, with 2.71-m [8 ft. 11 in.] arm)	5.26 m (17 ft. 3 in.)	5.26 m (17 ft. 3 in.)

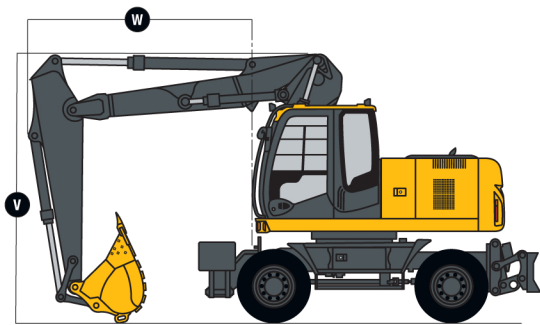
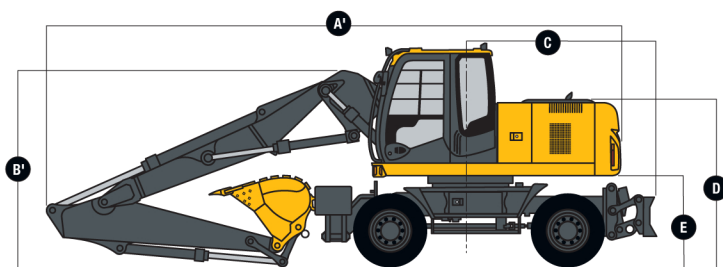
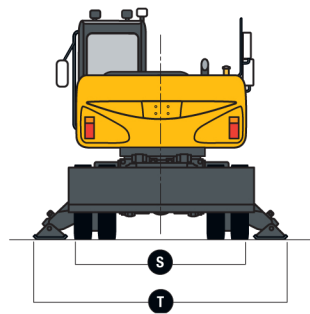
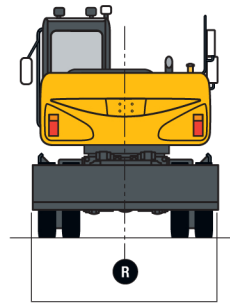
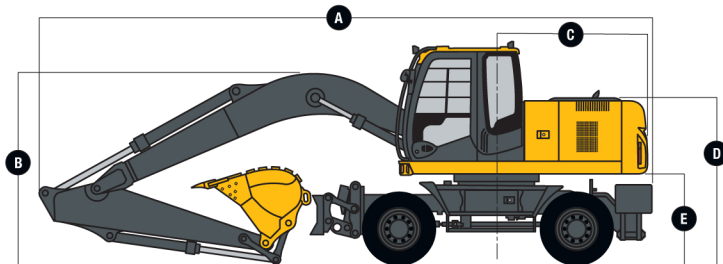
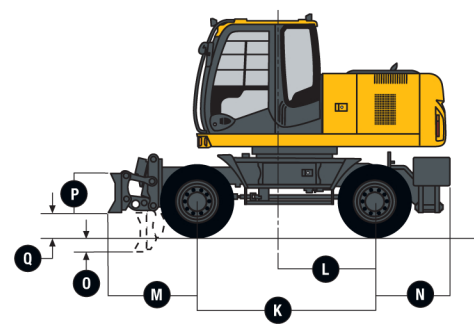
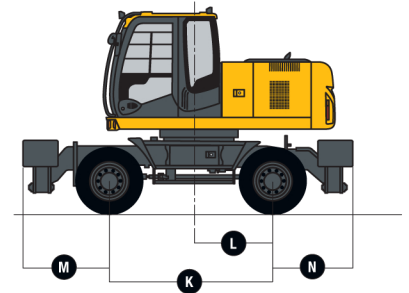
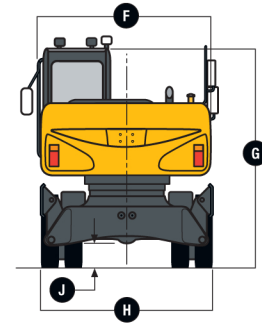

Lift Capacities

190D W

Boldface italic type indicates hydraulic-limited capacities; lightface type indicates stability-limited capacities, in lb. (kg). Ratings at bucket lift hook; machine equipped with 0.7-m³ (0.92 cu. yd.), 900-mm (35 in.) wide, 610-kg (1,345 lb.) bucket; 2.71-m (8 ft. 11 in.) arm; and standard gauge; and situated on firm, uniform surface. Total load includes weight of cables, hook. Etc. Figures do not exceed 87% of hydraulic capacities or 75% of weight needed to tip machine. All capacities are based on SAE J1097.

Load Point Height	3.05 m (10 ft.)		4.57 m (15 ft.)		6.10 m (20 ft.)		7.62 m (25 ft.)		9.14 m (30 ft.)	
	Over Front	Over Side	Over Front	Over Side	Over Front	Over Side	Over Front	Over Side	Over Front	Over Side

With monoblock boom and rear outriggers and front blade down

6.10 m (20 ft.)					3630 (8,003)	3630 (8,003)				
4.57 m (15 ft.)					4327 (9,538)	4326 (9,538)	3184 (7,018)	3183 (7,018)		
3.05 m (10 ft.)			6775 (14,935)	6774 (14,935)	5161 (11,377)	4632 (10,211)	4338 (9,563)	3172 (6,993)		
1.52 m (5 ft.)			8229 (18,141)	6880 (15,168)	5812 (12,813)	4388 (9,674)	4605 (10,152)	3059 (6,743)		
Ground Line			8631 (19,027)	6580 (14,507)	6152 (13,563)	4205 (9,271)	4719 (10,403)	2963 (6,533)		
-1.52 m (-5 ft.)	6166 (13,594)	6166 (13,594)	8101 (17,860)	6505 (14,342)	5982 (13,189)	4119 (9,081)	4476 (9,868)	2918 (6,432)		
-3.05 m (-10 ft.)	8500 (18,739)	8500 (18,739)	6858 (15,119)	6554 (14,448)	5159 (11,373)	4130 (9,104)				
-4.57 m (-15 ft.)			4608 (10,159)	4608 (10,159)						

With monoblock boom and 4 outriggers down

6.10 m (20 ft.)					3630 (8,003)	3630 (8,003)				
4.57 m (15 ft.)					4326 (9,538)	4326 (9,538)	3183 (7,018)	3183 (7,018)		
3.05 m (10 ft.)			6774 (14,935)	6774 (14,935)	5161 (11,377)	5161 (11,377)	4338 (9,563)	3711 (8,182)		
1.52 m (5 ft.)			8229 (18,141)	8179 (18,032)	5812 (12,813)	5155 (11,365)	4605 (10,152)	3595 (7,926)		
Ground Line			8631 (19,027)	7864 (17,337)	6152 (13,563)	4965 (10,947)	4719 (10,403)	3497 (7,710)		
-1.52 m (-5 ft.)	6166 (13,594)	6166 (13,594)	8101 (17,860)	7785 (17,162)	5982 (13,189)	4877 (10,751)	4476 (9,868)	3450 (7,606)		
-3.05 m (-10 ft.)	8500 (18,739)	8500 (18,739)	6858 (15,119)	6858 (15,119)	5159 (11,373)	4887 (10,775)				
-4.57 m (-15 ft.)			4608 (10,159)	4608 (10,159)						

With 2-piece boom and rear outriggers and front blade down

6.10 m (20 ft.)					3313 (7,303)	3313 (7,303)				
4.57 m (15 ft.)					3557 (7,841)	3557 (7,841)	2936 (6,472)	2936 (6,472)		
3.05 m (10 ft.)			5317 (11,722)	5317 (11,722)	4242 (9,352)	4242 (9,352)	3789 (8,353)	3306 (7,288)		
1.52 m (5 ft.)	8256 (18,202)	8256 (18,202)	7160 (15,785)	7080 (15,608)	5085 (11,210)	4599 (10,138)	4178 (9,210)	3250 (7,165)		
Ground Line	10 894 (24,017)	10 894 (24,017)	8255 (18,200)	7079 (15,606)	5760 (12,699)	4610 (10,163)	4521 (9,967)	3146 (6,936)		
-1.52 m (-5 ft.)	11 905 (26,247)	11 905 (26,247)	8514 (18,771)	7235 (15,950)	6049 (13,335)	4615 (10,175)	4649 (10,250)	3019 (6,656)		
-3.05 m (-10 ft.)	12 406 (27,351)	12 406 (27,351)	8734 (19,256)	7323 (16,144)	6214 (13,699)	4377 (9,650)				
-4.57 m (-15 ft.)	12 406 (27,351)	12 406 (27,351)	7881 (17,375)	7007 (15,448)						

With 2-piece boom and 4 outriggers down

6.10 m (20 ft.)					3313 (7,303)	3313 (7,303)				
4.57 m (15 ft.)					3557 (7,841)	3557 (7,841)	2936 (6,472)	2936 (6,472)		
3.05 m (10 ft.)			5317 (11,722)	5317 (11,722)	4242 (9,352)	4242 (9,352)	3789 (8,353)	3789 (8,353)		
1.52 m (5 ft.)	8256 (18,202)	8256 (18,202)	7160 (15,785)	7160 (15,785)	5085 (11,210)	5085 (11,210)	4178 (9,210)	3775 (8,323)		
Ground Line	10 894 (24,017)	10 894 (24,017)	8255 (18,200)	8081 (17,815)	5760 (12,699)	5234 (11,538)	4521 (9,967)	3676 (8,105)		
-1.52 m (-5 ft.)	11 905 (26,247)	11 905 (26,247)	8514 (18,771)	8212 (18,104)	6049 (13,335)	5377 (11,855)	4649 (10,250)	3559 (7,847)		
-3.05 m (-10 ft.)	12 406 (27,351)	12 406 (27,351)	8734 (19,256)	8585 (18,926)	6214 (13,699)	5159 (11,374)				
-4.57 m (-15 ft.)	12 406 (27,351)	12 406 (27,351)	7881 (17,375)	7881 (17,375)						

Buckets

A full line of buckets is offered to meet a wide variety of applications. Digging forces are with power boost. Replaceable cutting edges are available through John Deere parts. Optional side cutters add 150 mm (6 inches) to bucket widths.

Type Bucket	Bucket Width		Bucket Capacity		Weight		Bucket Dig Force		Arm Dig Force 2.71 m (8 ft. 11 in.)		Bucket Tip Radius		No. Teeth
	mm	in.	m ³	cu. yd.	kg	lb.	kN	lb.	kN	lb.	mm	in.	
General-Purpose	762	30	0.60	0.79	650	1,432	101.3	22,762	82.1	18,465	1473	58.0	4
High Capacity	914	36	0.76	1.00	735	1,621	101.3	22,762	82.1	18,465	1473	58.0	5
	1067	42	0.93	1.22	812	1,790	101.3	22,762	82.1	18,465	1473	58.0	5
	1219	48	1.09	1.43	896	1,976	101.3	22,762	82.1	18,465	1473	58.0	6
	Heavy-Duty	610	24	0.40	0.52	543	1,197	101.9	22,916	82.3	18,509	1463	57.61
Plate Lip	762	30	0.54	0.71	621	1,369	101.9	22,916	82.3	18,509	1463	57.61	4
	914	36	0.69	0.90	707	1,559	101.9	22,916	82.3	18,509	1463	57.61	5
	1067	42	0.83	1.09	785	1,731	101.9	22,916	82.3	18,509	1463	57.61	5
	1219	48	0.99	1.29	871	1,921	101.9	22,916	82.3	18,509	1463	57.61	6
Heavy-Duty	610	24	0.43	0.56	646	1,424	101.3	22,762	82.1	18,465	1473	58.0	4
High Capacity	762	30	0.58	0.76	723	1,593	101.3	22,762	82.1	18,465	1473	58.0	4
	914	36	0.74	0.97	808	1,782	101.3	22,762	82.1	18,465	1473	58.0	5
	1067	42	0.91	1.19	885	1,951	101.3	22,762	82.1	18,465	1473	58.0	5
Ditching	1524	60	0.87	1.14	577	1,271	141.1	31,720	91.2	20,505	1057	41.62	0

Specifications



Engine	220D W
Manufacturer and Model	Isuzu 4HK1X
Non-Road Emissions Standard	EPA Tier 3/EU Stage IIIA
Cylinders	4
Displacement	5.2 L (317 cu. in.)
SAE Net Rated Power @ 2,000 rpm	119 kW (159 hp)
Off-Level Capacity	70%
Aspiration	turbocharged and intercooled

Cooling
Direct-drive, suction-type fan

Powertrain	
Two-speed propel with creeper mode and automatic shift	
Travel Speed (maximum)	
Creeper	2.9 km/h (1.8 mph)
Low	7.4 km/h (4.6 mph)
High	27.5 km/h (17.1 mph)
Front Axle	all-wheel drive; can be locked hydraulically in any position
Oscillation	±7 deg.

Brakes maintenance-free wet-disc brakes on front and rear axles; fully hydraulic service brakes

Hydraulics	
Auxiliary hydraulic flow adjustable through monitor	
Main Pumps	2 variable-displacement axial-piston pumps
Pump Flow (maximum x 2)	189 L/m (49.9 gpm)
Pilot Pump	one gear
Maximum Rated Flow	27.7 L/m (7.3 gpm)
System Relief Pressure	3900 kPa (566 psi)
System Operating Pressure	
Implement Circuits	34 300 kPa (4,975 psi)
Travel Circuits	34 300 kPa (4,975 psi)
Swing Circuits	28 900 kPa (4,192 psi)
Controls	pilot levers, short stroke, low effort; hydraulic pilot controls with shutoff lever

Cylinders	Heat-treated, chrome-plated, polished cylinder rods, hardened steel (replaceable bushings) pivot pins		
	Bore	Rod Diameter	Stroke
Monoblock Boom (2)	120 mm (4.7 in.)	85 mm (3.3 in.)	1235 mm (48.6 in.)
2-Piece Boom (2)	125 mm (4.9 in.)	85 mm (3.3 in.)	1024 mm (40.3 in.)
Positioning (2), 2-Piece Boom	135 mm (5.3 in.)	95 mm (3.7 in.)	875 mm (34.4 in.)
Arm (1)	135 mm (5.3 in.)	95 mm (3.7 in.)	1475 mm (58.1 in.)
Bucket (1)	115 mm (4.5 in.)	80 mm (3.1 in.)	1060 mm (41.7 in.)

Electrical	
Voltage	24 volt
Number of Batteries (12 volt)	2
Alternator Rating	50 amp
Lights (6)	headlights (2), top of cab (2), rear of cab (1), and boom (1)
Driving Lights	headlights (2), turn signals and hazard lights, brake lights, and side-marker lights

Upperstructure/Swing Mechanism	
Swing Speed	12.2 rpm
Swing Torque	59 370 Nm (43,789 lb.-ft.)

Serviceability

220D W

Refill Capacities

Fuel Tank	355 L (94 gal.)
Cooling System	26 L (7 gal.)
Engine Oil with Filter	23 L (6 gal.)
Hydraulic Tank	200 L (53 gal.)
Hydraulic System	340 L (90 gal.)
Swing Drive	6.9 L (7.3 qt.)
Transmission Pump	0.95 L (1 qt.)
Transmission	2.5 L (3 qt.)
Axle	
Front	9.6 L (2.5 gal.)
Rear	13.1 L (3.7 gal.)
Front and Rear Hubs	2 x 2.5 L (2 x 2.6 qt.)

Operating Weights

With Full Fuel Tank; 79-kg (175 lb.) Operator;

0.7-m³ (0.92 cu. yd.), 900-mm (35 in.),

610-kg (1,345 lb.) General-Purpose Bucket;

2.91-m (9 ft. 7 in.) Arm; Standard Gauge,

and 4200-kg (8,929 lb.) Counterweight	<i>Monoblock Boom</i>	<i>2-Piece Boom</i>
Front and Rear Outrigger	22 629 kg (49,888 lb.)	23 588 kg (52,003 lb.)
Front Blade and Rear Outrigger	22 320 kg (49,207 lb.)	23 300 kg (51,368 lb.)

Operating Dimensions

	<i>Monoblock Boom</i>	<i>2-Piece Boom</i>
Arm Force	101.7 kN (22,873 lb.)	101.7 kN (22,873 lb.)
Bucket Digging Force	128.6 kN (28,904 lb.)	128.6 kN (28,904 lb.)
Lifting Capacity Over Front at Ground Level		
6.1-m (20 ft.) Reach*	7344 kg (16,190 lb.)	7107 kg (15,669 lb.)
A Maximum Reach	10.17 m (33 ft. 4 in.)	9.96 m (32 ft. 8 in.)
A' Maximum Reach at Ground Level	9.96 m (32 ft. 8 in.)	9.75 m (32 ft. 0 in.)
B Maximum Digging Depth	6.29 m (20 ft. 8 in.)	6.08 m (19 ft. 11 in.)
B' Maximum Digging Depth at 2.44-m (8 ft.) Flat Bottom	6.11 m (20 ft. 1 in.)	5.99 m (19 ft. 8 in.)
C Maximum Cutting Height	10.19 m (33 ft. 5 in.)	10.56 m (34 ft. 8 in.)
D Maximum Dumping Height	7.35 m (24 ft. 1 in.)	7.63 m (25 ft. 0 in.)
E Minimum Swing Radius	3.43 m (11 ft. 3 in.)	3.60 m (11 ft. 10 in.)
F Maximum Vertical Wall	5.60 m (18 ft. 4 in.)	5.25 m (17 ft. 3 in.)
G Tail Swing Radius	2.75 m (9 ft. 0 in.)	2.75 m (9 ft. 0 in.)

*With power boost.

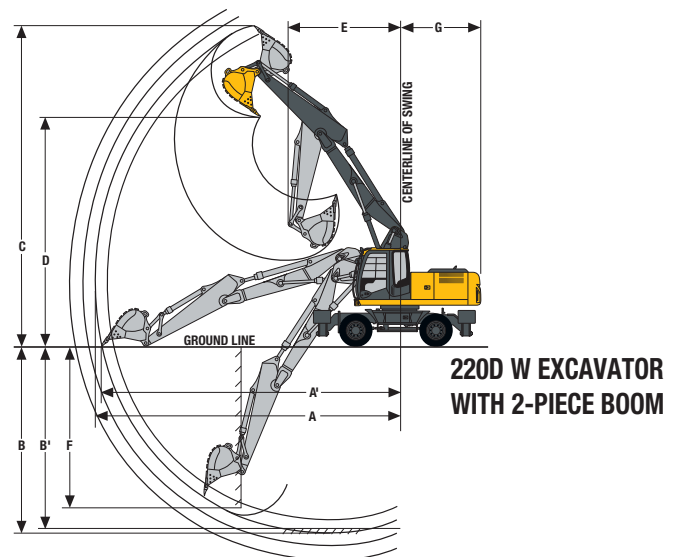
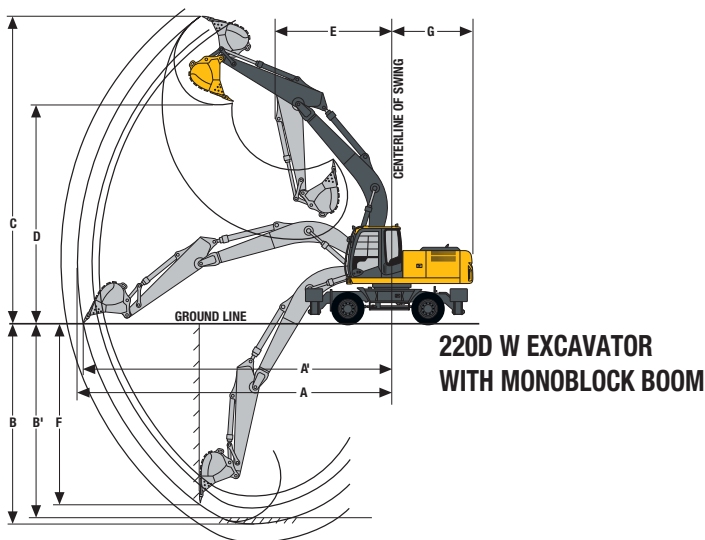

Machine Dimensions

220D W

With standard gauge. Dimensions are provided for both the front and rear outrigger configuration, and for the front blade and rear outrigger configuration.

	Monoblock Boom	2-Piece Boom
A Overall Length (with 2.91-m [9 ft. 7 in.] arm)	9.70 m (31 ft. 10 in.)	
A' Overall Length (with 2.91-m [9 ft. 7 in.] arm)		9.32 m (30 ft. 7 in.)
B Overall Height of Boom (with 2.91-m [9 ft. 7 in.] arm)	2.99 m (9 ft. 10 in.)	
B' Overall Height of Boom (with 2.91-m [9 ft. 7 in.] arm)		3.39 m (11 ft. 1 in.)
C Rear-End Swing Radius	2.75 m (9 ft. 0 in.)	2.75 m (9 ft. 0 in.)
D Engine Cover Height	2.52 m (8 ft. 3 in.)	2.52 m (8 ft. 3 in.)
E Counterweight Clearance	1.23 m (4 ft. 0 in.)	1.23 m (4 ft. 0 in.)
F Overall Width of Upperstructure	2.47 m (8 ft. 1 in.)	2.47 m (8 ft. 1 in.)
G Overall Height of Cab	3.17 m (10 ft. 5 in.)	3.17 m (10 ft. 5 in.)
H Overall Width of Tires	2.73 m (8 ft. 11 in.)	2.73 m (8 ft. 11 in.)
J Minimum Ground Clearance	0.33 m (13 in.)	0.33 m (13 in.)
K Wheelbase	2.75 m (9 ft. 0 in.)	2.75 m (9 ft. 0 in.)
L Swing Center to Rear Axle	1.30 m (4 ft. 3 in.)	1.30 m (4 ft. 3 in.)
M Front Overhang		
Front and Rear Outrigger	1.38 m (4 ft. 6 in.)	1.38 m (4 ft. 6 in.)
Front Blade and Rear Outrigger	1.36 m (4 ft. 5 in.)	1.36 m (4 ft. 5 in.)
N Rear Overhang	1.09 m (3 ft. 7 in.)	1.09 m (3 ft. 7 in.)
O Maximum Blade Lower	0.22 m (8 in.)	0.22 m (8 in.)
P Overall Height of Blade	0.60 m (24 in.)	0.60 m (24 in.)
Q Maximum Blade Raise	0.38 m (15 in.)	0.38 m (15 in.)
R Overall Width of Blade	2.53 m (8 ft. 4 in.)	2.53 m (8 ft. 4 in.)
S Overall Width with Outrigger Retracted	2.47 m (8 ft. 1 in.)	2.47 m (8 ft. 1 in.)
T Overall Width with Outrigger Extended	3.44 m (11 ft. 3 in.)	3.44 m (11 ft. 3 in.)
V Overall Height of Boom (traveling, with 2.91-m [9 ft. 7 in.] arm)	4.00 m (13 ft. 1 in.)	4.00 m (13 ft. 1 in.)
W Front Overhang (traveling, with 2.91-m [9 ft. 7 in.] arm)	3.50 m (11 ft. 6 in.)	3.50 m (11 ft. 6 in.)

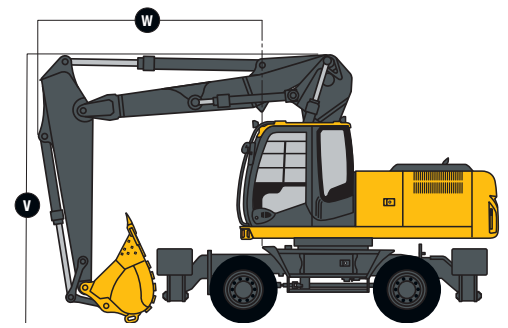
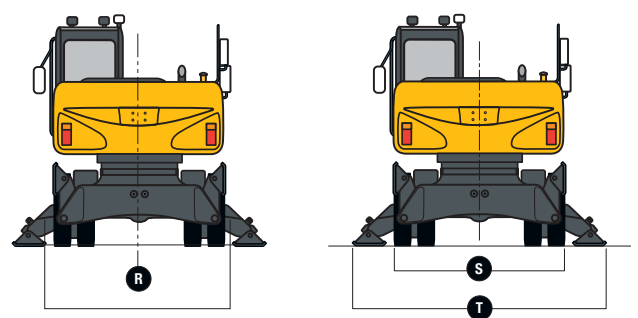
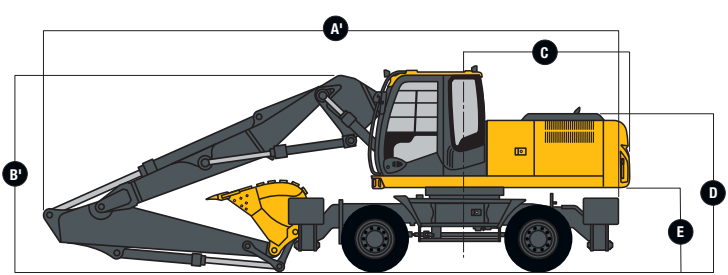
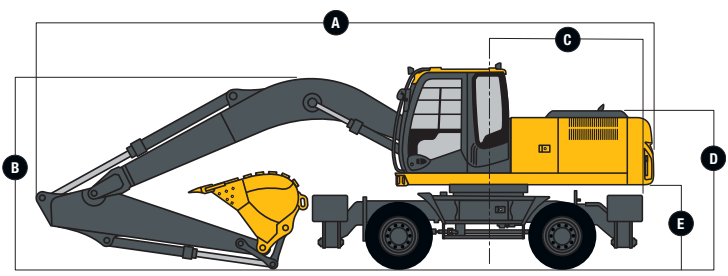
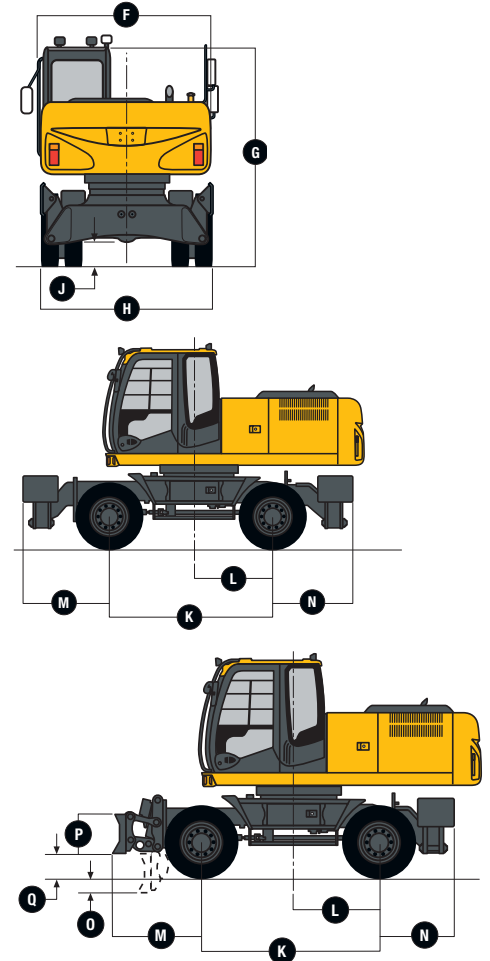

Lift Capacities

220D W

Boldface italic type indicates hydraulic-limited capacities; lightface type indicates stability-limited capacities, in lb. (kg). Ratings at bucket lift hook; machine equipped with 0.7-m³ (0.92 cu. yd.), 900-mm (35 in.) wide, 610-kg (1,345 lb.) bucket; 2.91-m (9 ft. 7 in.) arm; and standard gauge; and situated on firm, uniform surface. Total load includes weight of cables, hook. Etc. Figures do not exceed 87% of hydraulic capacities or 75% of weight needed to tip machine. All capacities are based on SAE J1097.

Load Point Height	3.05 m (10 ft.)		4.57 m (15 ft.)		6.10 m (20 ft.)		7.62 m (25 ft.)		9.14 m (30 ft.)	
	Over Front	Over Side	Over Front	Over Side	Over Front	Over Side	Over Front	Over Side	Over Front	Over Side
<i>With monoblock boom and rear outriggers and front blade down</i>										
7.62 m (25 ft.)					3089 (6,811)	3089 (6,811)				
6.10 m (20 ft.)					3931 (8,666)	3931 (8,666)	3683 (8,119)	3683 (8,119)		
4.57 m (15 ft.)					4525 (9,977)	4525 (9,977)	4243 (9,355)	4243 (9,355)		
3.05 m (10 ft.)			7449 (16,422)	7449 (16,422)	5544 (12,223)	5544 (12,223)	4701 (10,365)	4288 (9,454)		
1.52 m (5 ft.)			9715 (21,418)	9127 (20,122)	6620 (14,594)	5859 (12,917)	5239 (11,549)	4139 (9,125)	3558 (7,843)	3071 (6,771)
Ground Line			10 606 (23,383)	8829 (19,465)	7344 (16,190)	5648 (12,452)	5644 (12,442)	4021 (8,864)		
-1.52 m (-5 ft.)	6270 (13,824)	6270 (13,824)	10 447 (23,032)	8776 (19,348)	7522 (16,584)	5558 (12,254)	5732 (12,636)	3963 (8,738)		
-3.05 m (-10 ft.)	10 287 (22,679)	10 287 (22,679)	9554 (21,063)	8849 (19,509)	7065 (15,576)	5576 (12,293)	5214 (11,494)	3995 (8,808)		
-4.57 m (-15 ft.)			7676 (16,922)	7676 (16,922)	5546 (12,226)	5546 (12,226)				

With monoblock boom and 4 outriggers down

7.62 m (25 ft.)					3089 (6,811)	3089 (6,811)				
6.10 m (20 ft.)					3931 (8,666)	3931 (8,666)	3683 (8,119)	3683 (8,119)		
4.57 m (15 ft.)					4525 (9,977)	4525 (9,977)	4243 (9,355)	4243 (9,355)		
3.05 m (10 ft.)			7449 (16,422)	7449 (16,422)	5544 (12,223)	5544 (12,223)	4701 (10,365)	4540 (10,008)		
1.52 m (5 ft.)			9715 (21,418)	9715 (21,418)	6620 (14,594)	6215 (13,701)	5239 (11,549)	4389 (9,676)	3558 (7,843)	3263 (7,194)
Ground Line			10 606 (23,383)	9423 (20,775)	7344 (16,190)	6002 (13,232)	5644 (12,442)	4270 (9,413)		
-1.52 m (-5 ft.)	6270 (13,824)	6270 (13,824)	10 447 (23,032)	9369 (20,656)	7522 (16,584)	5910 (13,030)	5732 (12,636)	4212 (9,286)		
-3.05 m (-10 ft.)	10 287 (22,679)	10 287 (22,679)	9554 (21,063)	9444 (20,820)	7065 (15,576)	5928 (13,070)	5214 (11,494)	4244 (9,357)		
-4.57 m (-15 ft.)			7676 (16,922)	7676 (16,922)	5546 (12,226)	5546 (12,226)				

With 2-piece boom and rear outriggers and front blade down

7.62 m (25 ft.)					2687 (5,924)	2687 (5,924)				
6.10 m (20 ft.)					3051 (6,726)	3051 (6,726)	2896 (6,385)	2896 (6,385)		
4.57 m (15 ft.)					3535 (7,793)	3535 (7,793)	3760 (8,289)	3760 (8,289)		
3.05 m (10 ft.)			5680 (12,523)	5680 (12,523)	4594 (10,127)	4594 (10,127)	4229 (9,323)	4229 (9,323)		
1.52 m (5 ft.)			8489 (18,714)	8489 (18,714)	5916 (13,042)	5910 (13,030)	4921 (10,848)	4244 (9,356)		
Ground Line	12 497 (27,552)	12 497 (27,552)	10 447 (23,032)	9111 (20,086)	7107 (15,669)	5882 (12,968)	5622 (12,395)	4252 (9,374)		
-1.52 m (-5 ft.)	14 726 (32,465)	14 726 (32,465)	11 346 (25,013)	9280 (20,459)	7906 (17,429)	6037 (13,309)	6141 (13,538)	4097 (9,032)		
-3.05 m (-10 ft.)	15 702 (34,618)	15 702 (34,618)	11 617 (25,610)	9712 (21,411)	8228 (18,140)	5900 (13,007)				
-4.57 m (-15 ft.)	15 705 (34,624)	15 705 (34,624)	11 922 (26,284)	9470 (20,878)						

With 2-piece boom and 4 outriggers down

7.62 m (25 ft.)					2687 (5,924)	2687 (5,924)				
6.10 m (20 ft.)					3051 (6,726)	3051 (6,726)	2896 (6,385)	2896 (6,385)		
4.57 m (15 ft.)					3535 (7,793)	3535 (7,793)	3760 (8,289)	3760 (8,289)		
3.05 m (10 ft.)			5680 (12,523)	5680 (12,523)	4594 (10,127)	4594 (10,127)	4229 (9,323)	4229 (9,323)		
1.52 m (5 ft.)			8489 (18,714)	8489 (18,714)	5916 (13,042)	5916 (13,042)	4921 (10,848)	4467 (9,849)		
Ground Line	12 497 (27,552)	12 497 (27,552)	10 447 (23,032)	9620 (21,208)	7107 (15,669)	6186 (13,637)	5622 (12,395)	4500 (9,921)		
-1.52 m (-5 ft.)	14 726 (32,465)	14 726 (32,465)	11 346 (25,013)	9780 (21,562)	7906 (17,429)	6323 (13,939)	6141 (13,538)	4344 (9,576)		
-3.05 m (-10 ft.)	15 702 (34,618)	15 702 (34,618)	11 617 (25,610)	10 236 (22,566)	8228 (18,140)	6257 (13,794)				
-4.57 m (-15 ft.)	15 705 (34,624)	15 705 (34,624)	11 922 (26,284)	10 077 (22,215)						

Buckets

A full line of buckets is offered to meet a wide variety of applications. Digging forces are with power boost. Replaceable cutting edges are available through John Deere parts. Optional side cutters add 150 mm (6 inches) to bucket widths.

Type Bucket	Bucket Width		Bucket Capacity		Weight		Bucket Dig Force		Arm Dig Force		Bucket Tip Radius		No. Teeth
	mm	in.	m ³	cu. yd.	kg	lb.	kN	lb.	kN	lb.	mm	in.	
General-Purpose	762	30	0.60	0.79	650	1,432	128.6	28,904	101.7	22,873	1473	58.0	4
High Capacity	914	36	0.76	1.00	735	1,621	128.6	28,904	101.7	22,873	1473	58.0	5
	1067	42	0.93	1.22	812	1,790	128.6	28,904	101.7	22,873	1473	58.0	5
	1219	48	1.09	1.43	896	1,976	128.6	28,904	101.7	22,873	1473	58.0	6
	610	24	0.40	0.52	543	1,197	129.4	29,099	102.0	22,924	1463	57.61	4
Heavy-Duty Plate Lip	762	30	0.54	0.71	621	1,369	129.4	29,099	102.0	22,924	1463	57.61	4
	914	36	0.69	0.90	707	1,559	129.4	29,099	102.0	22,924	1463	57.61	5
	1067	42	0.83	1.09	785	1,731	129.4	29,099	102.0	22,924	1463	57.61	5
	1219	48	0.99	1.29	871	1,921	129.4	29,099	102.0	22,924	1463	57.61	6
Heavy-Duty High Capacity	610	24	0.43	0.56	646	1,424	128.6	28,904	101.7	22,873	1473	58.0	4
	762	30	0.58	0.76	723	1,593	128.6	28,904	101.7	22,873	1473	58.0	4
	914	36	0.74	0.97	808	1,782	128.6	28,904	101.7	22,873	1473	58.0	5
	1067	42	0.91	1.19	885	1,951	128.6	28,904	101.7	22,873	1473	58.0	5
	1219	48	1.06	1.39	970	2,139	128.6	28,904	101.7	22,873	1473	58.0	6
Ditching	1524	60	0.87	1.14	577	1,271	179.2	40,279	112.4	25,271	1057	41.62	0

190D W / 220D W WHEELED EXCAVATORS

Key: ● Standard equipment ▲ Optional or special equipment

See your John Deere dealer for further information.

190 220 Engine

- ● Meets EPA Tier 3/EU Stage IIIA emissions
- ● Auto-idle system
- ● Coolant recovery tank
- ● Dual element dry-type air filter
- ● Enclosed fan guard (conforms to SAE J1308)
- ● Engine coolant to -37 deg. C (-34 deg. F)
- ● Fuel filter with water separator
- ● Full-flow oil filter
- ● Radiator trash screen
- ● Turbocharger with charge air cooler
- ● Underhood muffler with vertical curved end exhaust stack

Hydraulic System

- ● Reduced-drift valve for boom down, arm in
- ● Auxiliary hydraulic valve section
- ● Spring-applied, hydraulically released automatic swing brake
- ● Brake valves for travel circuits
- ● Individual control of outriggers
- ▲ ▲ Auxiliary hydraulic lines
- ▲ ▲ Auxiliary pilot and electric controls
- ● Hydraulic filter restriction indicator kit
- ● Low-flow/medium-pressure-assist hydraulics

Undercarriage

- ● Brakes, 4 wheel, maintenance free, wet disc
- ● Creeper speed range
- ● Front axle, oscillating, lockable
- ▲ ▲ Front blade and rear outriggers (2)
- ▲ ▲ Outriggers (4)
- ● Parking brake
- ● Dual traction-type tires, 10.00-20, 16 PR with spacer
- ● Toolbox on left chassis

Upperstructure

- ● Right- and left-hand mirrors
- ● Vandal locks with ignition key: Cab door / Fuel cap / Service doors

Front Attachments

- 5.5-m (18 ft. 0 in.) monoblock boom with 2.71-m (8 ft. 11 in.) arm

190 220 Front Attachments (continued)

- 5.68-m (18 ft. 8 in.) monoblock boom with 2.91-m (9 ft. 7 in.) arm
- ▲ Variable-geometry, 2-piece boom with 2.71-m (8 ft. 11 in.) arm
- ▲ Variable-geometry, 2-piece boom with 2.91-m (9 ft. 7 in.) arm
- Centralized lubrication system
- Dirt seals on all bucket pins
- ▲ ▲ Buckets: Ditching / General purpose / General-purpose high capacity / Heavy duty / Heavy-duty high capacity / Side cutters and teeth

Operator's Station

- ● Adjustable independent control positions (levers-to-seat, seat-to-pedals)
- ● AM/FM radio
- ● Auto climate control/air conditioner, 5.9 kW (20,000 Btu/hr.), with heater and pressurizer
- ● Built-in Operator's Manual storage compartment and manual
- ● Cell-phone power outlet, 12 volt, 60 watt, 5 amp
- ● Coat hook
- ● Deluxe suspension cloth seat with 100-mm (4 in.) adjustable armrests
- ● Floor mat
- ● Front windshield wiper with intermittent speeds
- ● Gauges (illuminated): Engine coolant / Fuel / Brake pressure
- ● Horn, electric
- ● Hourmeter, electric
- ● Hydraulic shutoff lever, all controls
- ● Hydraulic warm-up control
- ● Interior light
- ● Large cup holder
- ● Machine Information Center (MIC)
- ● Mode selectors (illuminated): Power modes (3) / Work mode (1)
- ● High/low travel mode with creeper range

190 220 Operator's Station (continued)

- ● Monitor system with alarm features: Auto-idle light / Brake pressure audible alarm / Engine air cleaner restriction indicator light / Engine coolant temperature indicator light with audible alarm / Engine oil pressure indicator light with audible alarm / Low alternator charge indicator light / Low fuel indicator light / Speedometer / Trip meter / Wiper mode indicator / Work lights on indicator / Work mode indicator
- ▲ ▲ Hydraulic oil filter restriction indicator light
- ● Motion alarm with cancel switch (conforms to SAE J994)
- Power-boost switch on right control lever
- ● SAE 2-lever control pattern
- ● Seat belt, 51 mm (2 in.), retractable
- ▲ ▲ Seat belt, 76 mm (3 in.), non-retractable
- ● Tinted glass
- ● Transparent tinted overhead hatch
- ● Tilting steering column
- ● Sun visor
- ● Windshield washer/wiper with constant and intermittent speeds
- ▲ ▲ 24- to 12-volt D.C. radio converters, 10 amp
- ▲ ▲ Window vandal protection covers

Electrical

- ● 50-amp alternator
- ● Blade-type multi-fused circuits
- ● Positive terminal battery covers
- JDLINK™ Ultimate wireless communication system with 3 years of service (available only in U.S. and Canada)
- ▲ JDLINK wireless communication system (available only in U.S. and Canada)

Lights

- ● Headlights (2)
- ● Work lights, top of cab (2), rear of cab (1), and boom (1)
- ● Turn signals / Hazard lights
- ● Brake lights
- ● Side marker lights

CONTROL OWNING AND OPERATING COSTS

Customer Personal Service (CPS) is part of our proactive, fix-before-fail strategy on machine maintenance that will help control costs, increase profits, and reduce stress. Included in this comprehensive lineup of ongoing programs and services are:

Customer Support Advisors (CSAs) lend a *personal* touch to Customer Personal Service (CPS). Certified CSAs have the knowledge and skills for helping make important decisions on machine maintenance and repair. Their mission is to help you implement a plan that's right for *your* business and take the burden of machine maintenance off your shoulders.

Fluid analysis program tells you what's going on inside *all* of your machine's major components so you'll know if there's a problem *before* you see a decline in performance. Fluid analysis is included in most extended coverage and preventive-maintenance agreements.

Component life-cycle data gives you vital information on the projected life span of components and lets you make informed decisions on machine maintenance by telling you approximately how many hours of use you can expect from an engine, transmission, or hydraulic

pump. This information can be used to preempt catastrophic downtime by servicing major components at about 80 percent of their life cycle.

Preventive Maintenance (PM) agreements give you a fixed cost for maintaining a machine for a given period of time. They also help you avoid downtime by ensuring that critical maintenance work gets done right and on schedule. On-site preventive maintenance service performed where and when you need it helps protect you from the expense of catastrophic failures and lets you avoid waste-disposal hassles.

Extended coverage gives you a fixed cost for machine repairs for a given period of time so you can effectively manage costs. Whether you work in a severe-service setting or just want to spread the risk of doing business, this is a great way to custom-fit coverage for your operation. And an extended coverage contract also travels well because it's backed by John Deere and is honored by *all* Deere construction dealers.



JOHN DEERE

DKAXDW Litho in U.S.A. (10-04)

Net engine power is with standard equipment including air cleaner, exhaust system, alternator, and cooling fan at test conditions specified per ISO9249. No derating is required up to 3050-m (10,000 ft.) altitude.

Specifications and design subject to change without notice. Wherever applicable, specifications are in accordance with SAE standards. Except where otherwise noted, these specifications are based on units with 0.7-m³ (0.92 cu. yd.), 900-mm (35 in.) buckets; full fuel tank; and 79-kg (175 lb.) operator; a 2.71-m (8 ft. 11 in.) arm on the 190D W; and a 2.91-m (9 ft. 7 in.) arm on the 220D W.

