

PowerTech™ M

3029TFG89 Diesel Engine

Generator Drive Engine Specifications



3029TFG89 shown

Engine dimensions

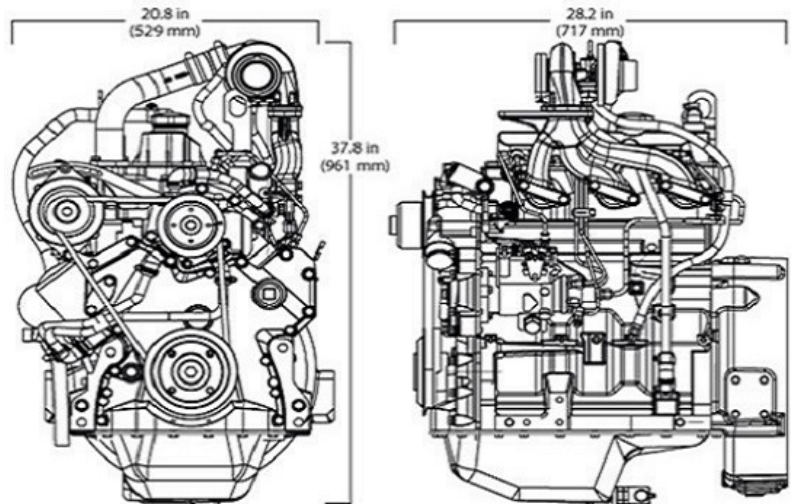

Dimensions may vary according to options selected. Call your distributor for more information.

Certifications

- CARB
- EPA Interim Tier 4
- EU Stage III A

General data

Model	3029TFG89	Length - mm (in) to rear of block	717 (28.2)
Number of cylinders	3	Width - mm (in)	529 (20.8)
Displacement - L (cu in)	2.9 (177)	Height-- mm (in)	961 (37.8)
Bore and Stroke-- mm (in)	106 x 110 (4.17 x 4.33)	Weight, dry-- kg (lb)	316 (697)
Compression Ratio	17.2 : 1		
Engine Type	In-line, 4-cycle		
Aspiration	Turbocharged		

Performance data range

Rated speed	Engine power				Generator efficiency	Rated fan power		Power factor	Calculated generator set output			
	Prime		Standby			kW	hp		Prime		Standby	
	kW	hp	kW	hp					kWe*	kVA	kWe	kVA
60(1800)	31	42	35	47	88-92	2.2	3	0.8	25-27	32-34	28-30	35-37

Prime power is the nominal power an engine is capable of delivering with a variable load for an unlimited number of hours per year when applied in conformance with ISO 8528-1. This rating conforms to ISO3046 and SAE J1995.

Standby power is the maximum engine power available at varying load factors for up to 200 hours per year when applied in conformance with ISO 8528-1. This rating conforms to ISO 3046 and SAE J1995. The calculated generator set rating range for standby applications is based on minimum engine power (nominal -5 percent) to provide 100 percent meet-or-exceed performance for assembled standby gen-sets.

*Electrical power is calculated from the typical generator efficiency and fan power percentages shown. Applications may vary.

Features and benefits

Fixed Geometry Turbocharger

- Fixed geometry turbochargers are sized for a specific power range and optimized to provide excellent performance across the entire torque curve. They are also designed to maximize fuel economy between the engine's rated speed and peak torque.

Turbocharged

- In turbocharged engines, the air is pre-compressed. Due to the higher pressure, more air is supplied into the combustion chamber, allowing a corresponding increase in fuel injection, which results in greater engine output.

Mechanical Rotary Pump

- The timing and fuel injection pressures are optimized to maximize performance and fuel economy at a given rated speed.

2-Valve Cylinder Head

- Cross-flow head design provides excellent breathing from a lower-cost 2-valve cylinder head.

Compact Size

- Horsepower/displacement ratio is best-in-class
- Lower installed cost
- Mounting points are the same as previous engine models