

PowerTech™ M

4045HFG81 Diesel Engine

Generator Drive Engine Specifications

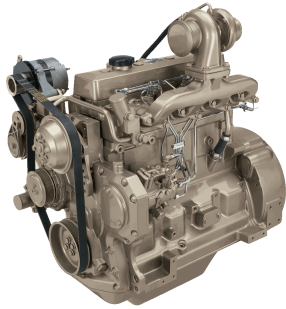

4045HFG81 shown

Engine dimensions

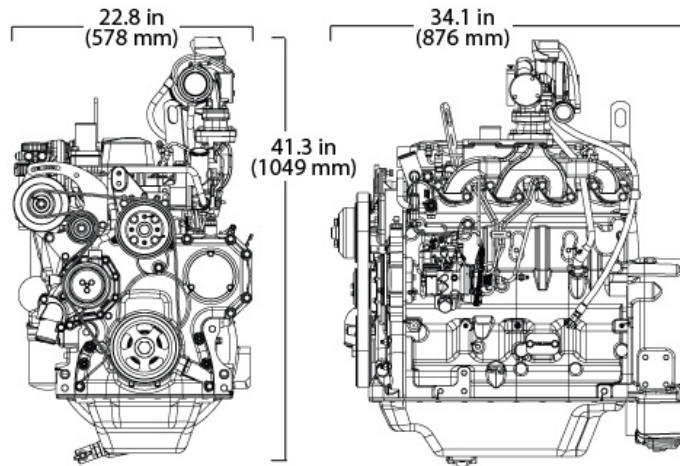

Dimensions may vary according to options selected. Call your distributor for more information.

Certifications

EPA Tier 3
EU Stage III A

General data

Model	4045HFG81	Length - mm (in) to rear of block	867 (34.1)
Number of cylinders	4	Width - mm (in)	578 (22.8)
Displacement - L (cu in)	4.5 (275)	Height-- mm (in)	1049 (41.3)
Bore and Stroke-- mm (in)	106 x 127 (4.17 x 5.00)	Weight, dry-- kg (lb)	491 (1082)
Compression Ratio	19.0 : 1		
Engine Type	In-line, 4-cycle		
Aspiration	Turbocharged and air-to-air aftercooled		

Performance data range

Rated speed	Engine power				Generator efficiency	Rated fan power		Power factor	Calculated generator set output			
	Prime		Standby			kW	hp		Prime		Standby	
	kW	hp	kW	hp					kWe*	kVA	kWe	kVA
60(1800)	59	79	65	87	88-92	15.5	21	0.8	38-40	48-50	43-45	54-57
50(1500)	56	75	61	82	88-92	9	12	0.8	41-43	51-54	46-48	57-60

Prime power is the nominal power an engine is capable of delivering with a variable load for an unlimited number of hours per year. This rating conforms to ISO3046 and SAE J1995.

Standby power is the maximum engine power available at varying load factors for up to 200 hours per year when applied to conform with ISO 8528-1. This rating conforms to ISO 3046 and SAE J1995. Calculated generator set rating range for standby applications is based on minimum engine power (nominal -5 percent) to provide 100 percent meet-or-exceed performance for assembled standby generator sets.

*Electrical power is calculated from the typical generator efficiency and fan power percentages shown. Applications may vary.

Features and benefits

Jet Fuel Capable

- The John Deere jet fuel capable engines run on military, arctic, and aviation fuel, including Jet A, Jet A-1, JP-5, and JP-8. If you need to switch back to diesel fuel, just fill up the tank and go.

Fixed Geometry Turbocharger

- Fixed geometry turbochargers are sized for a specific power range and optimized to provide excellent performance across the entire torque curve. They are also designed to maximize fuel economy between the engine's rated speed and peak torque.

Turbocharged

- In turbocharged engines, the air is pre-compressed. Due to the higher pressure, more air is supplied into the combustion chamber, allowing a corresponding increase in fuel injection, which results in greater engine output.

Mechanical Rotary Pump

- The timing and fuel injection pressures are optimized to maximize performance and fuel economy at a given rated speed.

2-Valve Cylinder Head

- Cross-flow head design provides excellent breathing from a lower-cost 2-valve cylinder head.

Compact Size

- Horsepower/displacement ratio is best-in-class
- Lower installed cost
- Mounting points are the same as previous engine models

Additional Features

- Self-adjusting poly-vee fan drive
- Forged-steel connecting rods
- Either-side service
- Optional balancer shafts