

PowerTech™ EWX 4045TFC03 Diesel Engine

Industrial Engine Specifications



4045TFC03 shown

Engine dimensions

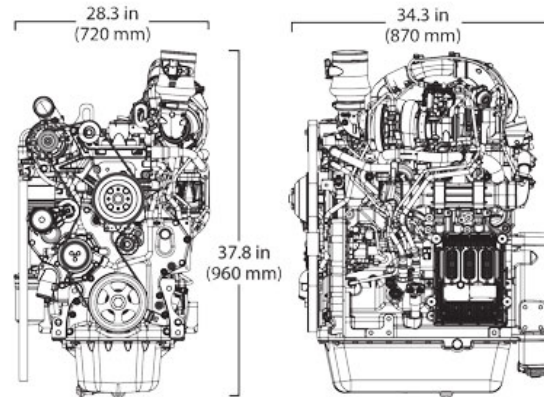

Dimensions may vary according to options selected. Call your distributor for more information.

Emissions

CARB
EPA Tier 4
EU Stage III B

General data

Model	4045TFC03	Length - mm (in)	870 (34.3)
Number of cylinders	4	Width - mm (in)	720 (28.3)
Displacement - L (cu in)	4.5 (275)	Height-- mm (in)	960 (37.8)
Bore and Stroke-- mm (in)	106 x 127 (4.17 x 5.00)	Weight, dry - kg (lb)	510 (1124)
Compression Ratio	19.0 : 1		
Engine Type	In-line, 4-cycle		
Aspiration	Turbocharged		

Performance data range

Application ratings	Continuous
Rated power/Rated speed	55 kW(74 hp) @2200-2400rpm
Peak power	55 kW (74 hp) @2200-2400rpm
Power bulge	0% @ NA rpm
Peak torque	304 N.m (224ft-lb) @1600rpm
Torque rise	39%

The Industrial Continuous engine power rating is for applications that operate with constant load and speed, except for short periods during startup or shutdown.

Power output is within + or - 5% at standard SAE J 1995 and ISO 3046.

DOC/DPF Dimensions

Size	2
Diameter - mm (in)	209 (8.2)
Length - mm (in)	573 (22.6)
Weight - kg (lb)	20 (44.1)

See your John Deere Power Systems engine distributor for more information on available filter size options.

Features and Benefits

Ready to Run. Stage V.

- John Deere is ready to work, ready to generate, and ready to run with engines meeting EU Stage V emissions regulations. This means OEM customers currently using a John Deere engine with a diesel particulate filter (DPF) won't have to re-engineer their machine to meet the requirements of Stage V regulations. John Deere has been using DPF technology since Interim Tier 4/Stage III B, and is well positioned to help customers transition to the EU's Stage V standard. We have extensive experience with the development and integration of DPFs in both John Deere and OEM equipment, with more than 425 million DPF hours in the field.*

* Data compiled September 2016



High-Pressure Common-Rail (HPCR) and Engine Control Unit (ECU)

- The HPCR fuel system provides variable common-rail pressure and higher injection pressures up to 1,600 bar (23,000 psi). It also controls fuel injection timing and provides precise control for the start, duration, and end of injection.

2-Valve Cylinder Head

- Cross-flow head design provides excellent breathing from a lower-cost 2-valve cylinder head.

Turbocharged

- In turbocharged engines, the air is precompressed. Due to the higher pressure, more air is supplied into the combustion chamber, allowing a corresponding increase in fuel injection, which results in greater engine output.

Wastegated Turbocharger

- Wastegated turbochargers are designed to develop more airflow at lower engine speeds to improve low-speed torque. The wastegate control device bleeds off a portion of the exhaust flow at higher engine speeds. Wastegated turbos deliver improved transient response and higher peak torque without compromising engine envelope size. They also provide the lowest installed cost across a given power range.

Exhaust Filters

- These engines utilize a catalyzed exhaust filter that contains a diesel oxidation catalyst (DOC) and a diesel particulate filter (DPF). The DOC reacts with exhaust gases to reduce carbon monoxide, hydrocarbons, and some particulate matter (PM). The downstream DPF traps and holds the remaining PM. Trapped particles are oxidized within the DPF through a continuous cleaning process called passive regeneration. Passive regeneration occurs during normal operating conditions when heat from the exhaust stream and catalysts within the exhaust filter trigger the oxidation of the trapped PM. If passive regeneration cannot be achieved due to low temperature, load, or speed, then PM is removed using active regeneration — an automatic cleaning process controlled by the exhaust temperature management system.