

# PowerTech™ PVX 4045HFC93 Diesel Engine

Industrial Engine Specifications



4045HFC93 shown

## Engine dimensions

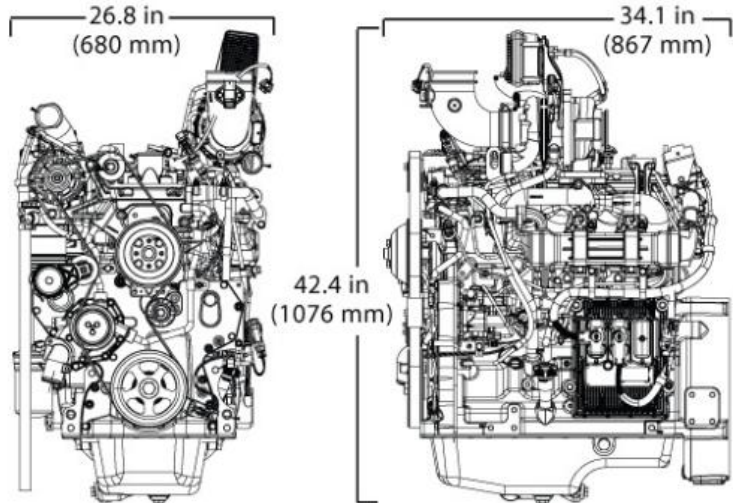

Dimensions may vary according to options selected. Call your distributor for more information.

## Emissions

CARB  
EPA Interim Tier 4  
EU Stage III B

## General data

Model	4045HFC93	Length - mm (in)	867 (34.1)
Number of cylinders	4	Width - mm (in)	680 (26.8)
Displacement - L (cu in)	4.5 (275)	Height-- mm (in)	1076 (42.4)
Bore and Stroke-- mm (in)	106 x 127 (4.17 x 5.00)	Weight, dry - kg (lb)	566 (1248)
Compression Ratio	16.5 : 1		
Engine Type	In-line, 4-cycle		

Aspiration Turbocharged and air-to-air aftercooled

## Performance data range

Application ratings	Intermittent	Heavy Duty	Continuous
Rated power/Rated speed	116-129 kW(156-173 hp) @2200-2400rpm	104 kW(139 hp) @2200-2400rpm	93-104 kW(125-139 hp) @2200-2400rpm
Peak power	117-129 kW (157-173 hp) @2100-2400rpm	107-112 kW (143-150 hp) @1900-2200rpm	96-106 kW (129-142 hp) @1900-2200rpm
Power bulge	0% @ NA rpm	2-8% @ 2000-2200rpm	1-2% @ 2000-2200rpm
Peak torque	645 N.m (476ft-lb) @1600rpm	552-601 N.m (407-443ft-lb) @1600rpm	537-552 N.m (396-407ft-lb) @1600rpm
Torque rise	26-28%	33%	33%

The Industrial Intermittent engine power rating is for applications that operate at varying loads and speeds, and do not fit the Industrial Heavy-Duty rating information.

Some applications require Industrial Heavy-Duty engine power ratings. Please contact your John Deere Power Systems engine distributor for more information.

The Industrial Continuous engine power rating is for applications that operate with constant load and speed, except for short periods during startup or shutdown.

Power output is within + or - 5% at standard SAE J 1995 and ISO 3046.

## DOC/DPF Dimensions

Size	8
Diameter - mm (in)	307.18 (12.1)
Length - mm (in)	636.95 (25.1)
Weight - kg (lb)	NA

See your John Deere Power Systems engine distributor for more information on available filter size options.

## Features and Benefits

### Variable Geometry Turbocharger (VGT)

- Varies exhaust pressure based on load and speed to ensure proper EGR flow. The combination of the cooled EGR and VGT provide low-speed torque, quicker transient response, higher-peak torque, and world-class fuel economy.

### Cooled Exhaust Gas Recirculation (EGR)

- EGR cools and mixes measured amounts of cooled exhaust gas with incoming fresh air to lower peak combustion temperatures, thereby reducing Nox.

### Exhaust Filters

- These engines utilize a catalyzed exhaust filter that contains a diesel oxidation catalyst (DOC) and a diesel particulate filter (DPF). The DOC reacts with exhaust gases to reduce carbon monoxide, hydrocarbons, and some particulate matter (PM). The downstream DPF traps and holds the remaining PM. Trapped particles are oxidized within the DPF through a continuous cleaning process called passive regeneration. Passive regeneration occurs during normal operating conditions when heat from the exhaust stream and catalysts within the exhaust filter trigger the oxidation of the trapped PM. If passive regeneration cannot be achieved due to low temperature, load, or speed, then PM is removed using active regeneration an automatic cleaning process controlled by the exhaust temperature management system. Engines below 130 kW (174 hp) use an in-cylinder dosing system for active regeneration, while larger engines use an external dosing system.

### High-Pressure Common-Rail (HPCR) and Engine Control Unit (ECU)

- The HPCR fuel system provides variable common-rail pressure and higher injection pressures up to 1,975 bar (29,000 psi). It also controls fuel injection timing and provides precise control for the start, duration, and end of injection.

### 4-Valve Cylinder Head

- The 4-valve cylinder head provides excellent airflow resulting in greater low-speed torque and better transient response time by utilizing a cross-flow design.

### Air-to-Air Aftercooled

- This is the most efficient method of cooling intake air to help reduce engine emissions while maintaining low-speed torque, transient response time, and peak torque. It enables an engine to meet emissions regulations with better fuel economy and the lowest installed costs.

### Compact Size

- Simplifies installation; Mounting points are the same as previous models

### John Deere Electronic Engine Controls

- Faster engine control unit (ECU) manages both the engine and the exhaust filter; Four times the memory, twice the RAM, and double the processing speed; Input/output capability has increased 40%; JDLink™ lets you monitor, protect, and maintain your equipment 24/7; Premium software option integrates with equipment or vehicles to reduce engineering and installation costs

### Additional Features

- Glow plugs; Gear-driven auxiliary drives; 500-hour oil change; Self-adjusting poly-vee fan drive; Optional factory installed variable-speed fan drive improves fuel economy and reduces noise levels; R.H. and L.H. engine-mounted final fuel filters; Optional low-pressure fuel system with electrical transfer pump and auto-prime feature