

PowerTech™ E

6068HFG82 Diesel Engine

Generator Drive Engine Specifications

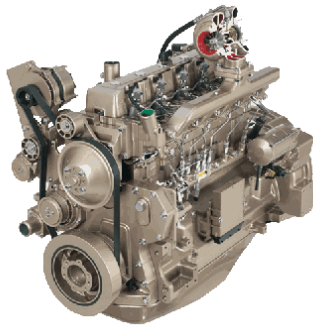

6068HFG82 shown

Engine dimensions

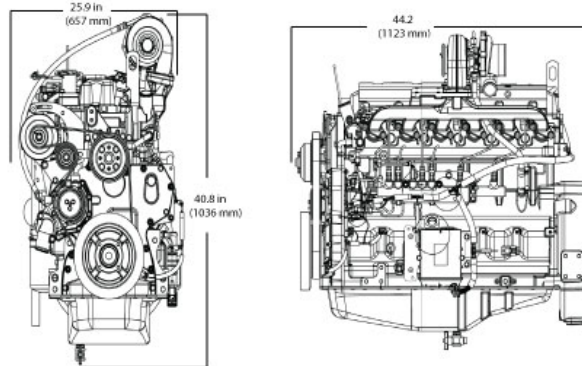

Dimensions may vary according to options selected. Call your distributor for more information.

Certifications

EPA Tier 3
EU Stage III A

General data

Model	6068HFG82	Length - mm (in) to rear of block	1123 (44.2)
Number of cylinders	6	Width - mm (in)	657 (25.9)
Displacement - L (cu in)	6.8 (415)	Height-- mm (in)	1036 (40.8)
Bore and Stroke-- mm (in)	106 x 127 (4.17 x 5.00)	Weight, dry-- kg (lb)	608 (1340)
Compression Ratio	19.0:1		
Engine Type	In-line, 4-cycle		
Aspiration	Turbocharged and air-to-air aftercooled		

Performance data range

Rated speed Hz(rpm)	Engine power				Generator efficiency %	Rated fan power		Power factor	Calculated generator set output			
	Prime		Standby			kW	hp		Prime		Standby	
	kW	hp	kW	hp					kWe*	kVA	kWe	kVA
50(1500)	139-184	186-247	153-202	205-271	88-92	9.0-11.4	12-15	0.8	112-161	140-201	125-178	156-222
60(1800)	143-194	192-260	157-212	211-284	88-92	15-18.2	20-24	0.8	110-165	137-206	122-181	152-227

Prime power is the nominal power an engine is capable of delivering with a variable load for an unlimited number of hours per year. This rating conforms to ISO3046 and SAE J1995.

Standby power is the maximum engine power available at varying load factors for up to 200 hours per year when applied to conform with ISO 8528-1. This rating conforms to ISO 3046 and SAE J1995. Calculated generator set rating range for standby applications is based on minimum engine power (nominal -5 percent) to provide 100 percent meet-or-exceed performance for assembled standby generator sets.

*Electrical power is calculated from the typical generator efficiency and fan power percentages shown. Applications may vary.

Features and benefits

Fixed Geometry Turbocharger

- Fixed geometry turbochargers are sized for a specific power range and optimized to provide excellent performance across the entire torque curve. They are also designed to maximize fuel economy between the engine's rated speed and peak torque.

High Pressure Common Rail Fuel System (HPCR) and Engine Control Unit (ECU)

- The HPCR fuel system provides variable common rail pressure, multiple injections, and higher injection pressures, up to 1,600 bar (23,000 psi). It also controls fuel injection timing and provides precise control for the start, duration, and end of injection.

2-Valve Cylinder Head

- Cross-flow head design provides excellent breathing from a lower-cost 2-valve cylinder head

Air-to-Air Aftercooled

- This is the most efficient method of cooling intake air to help reduce engine emissions while maintaining low-speed torque, transient response time, and peak torque. It enables an engine to meet emissions regulations with better fuel economy and the lowest installed costs

Compact Size

- Horsepower/displacement ratio is best-in-class
- Lower installed cost
- Mounting points are the same as previous engine models

John Deere Electronic Engine Controls

- Electronic engine controls monitor critical engine functions, providing warning and/or shutdown to prevent costly repairs and eliminate the need for add-on governing components, all lowering total installed costs.

Additional Features

- Self-adjusting poly-vee fan drive
- Forged-steel connecting rods
- Replaceable wet-type cylinder liners
- Either-side service
- Gear Driven Auxiliary Drive