

QRG 2680H QUICK REFERENCE GUIDE

NOTE: Use this as a reference guide. For further details on procedures, see the Operator's Manual provided with the machine.

Connect Hydraulics

SCV	Function
I	Front Wheel Lift
II	Rear Roller Lift
III	Main Frame Lift
IV	Wings
V	Hitch Jack Lift
VI	Optional Scraper

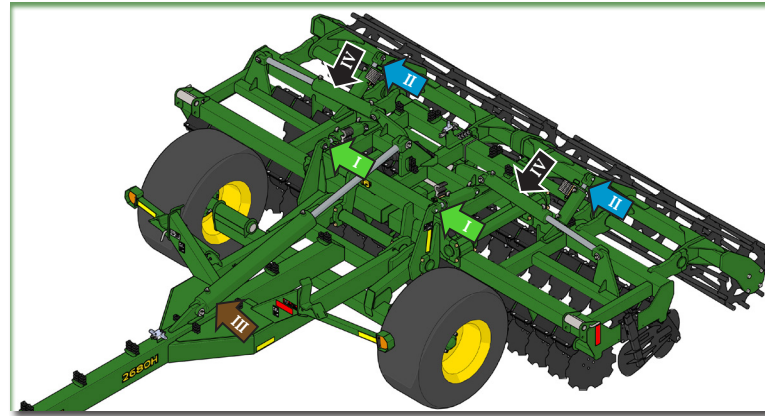

Engine Horsepower Requirements

Machine Size	Tractor Power
16 ft	220 hp Minimum
18 ft	250 hp Minimum
21 ft	290 hp Minimum
24 ft	340 hp Minimum

Engine horsepower requirements may vary depending on soil conditions and digging depth.

IMPORTANT: If proper responses are not observed during folding or unfolding procedure, see Make Proper Hose Connections in the Operator's Manual.

Unfolding Sequence

1. Remove transport lock pins (A) from the cradles and place in storage location.
2. Extend SCV III until wings clear the cradles.
3. Extend SCV IV to unfold the wings.
4. Place both SCV III and SCV IV into the FLOAT position to lower the machine.

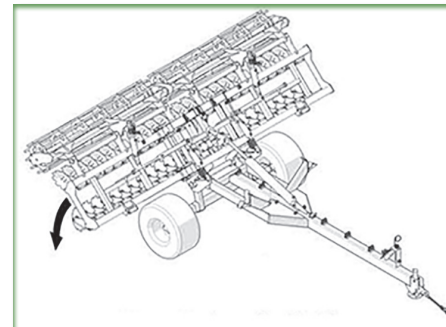
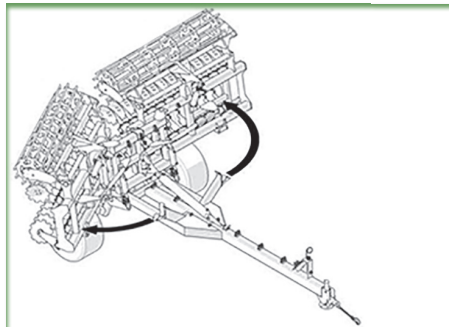
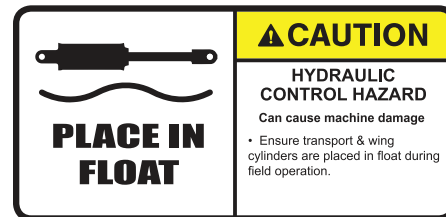

Folding Sequence

- A. Take SCV III and SCV IV out of the FLOAT position and retract SCV III until wing is perpendicular to the ground.
- B. Retract SCV IV to fold wings inward until touching inner edge of cradles.
- C. Retract SCV III until resting in cradles.
- D. Insert and lock transport pins in place.

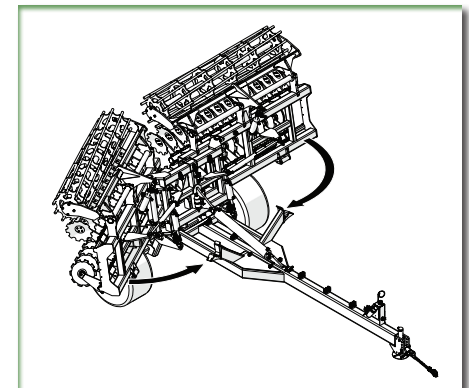
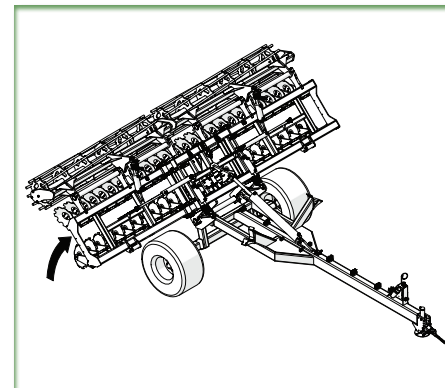

QRG 2680H QUICK REFERENCE GUIDE

Adjust Operating Depth

Depth	Number of Stops
2.0"	9
2.5"	8
3.0"	7
3.5"	6
4.0"	5
4.5"	4
5.0"	3
5.5"	2
6.0"	1

IMPORTANT

CYLINDER STOP INSTRUCTIONS

Can cause machine damage

- Use cylinder stops closest to the clevis first.



90-44-0247

- To adjust depth, raise wheel cylinders (A) and basket cylinders (B).
- Add cylinder stops for shallower depth.
- Remove stops for deeper depth.

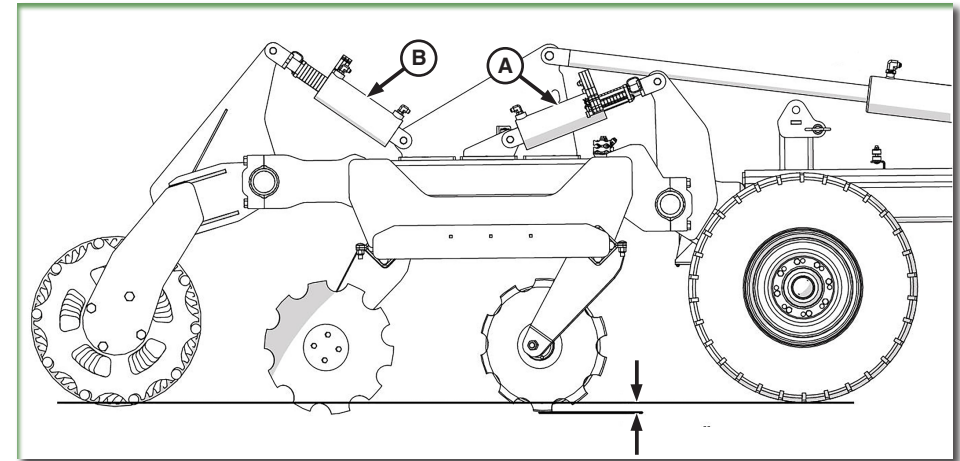

In-Field Operation

- Ensure SCV III (Main Frame Lift) and SCV IV (Wings) are in the FLOAT position.
- Adjust operating speed between 10 to 14 mph.
- For headland turns, make skip row passes at the desired operating depth.
- Ensure a minimum of 6 to 8 inches overlap.



PLACE IN
FLOAT

CAUTION

HYDRAULIC CONTROL HAZARD
Can cause machine damage

• Ensure transport & wing cylinders are placed in float during field operation.

- When backing up, raise the machine using SCV I and SCV II. If machine is equipped with the rubber roller attachment, raise the scraper using SCV VI.

IMPORTANT: Do not reverse machine in ground or damage may occur.
Do not use SCV III (Main Lift) during reversals and turns.
Do not make sharp turns causing tires to contact the hitch.

Machine Setting	Fall Tillage	Spring Tillage
Depth	3.5—4.5 in	2—3 in
Soil Deflector	Storage Position (High Residue)	Engaged Position (Low Residue)



Soil Deflector (Storage Position)

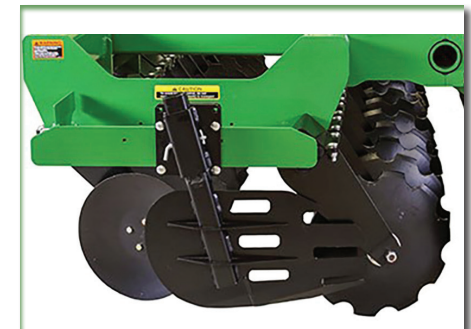

Soil Deflector (Engaged Position)