

E-SERIES
KNUCKLEBOOM LOADERS



JOHN DEERE

337E / 437E



**STEP UP
THE PACE**



NEED HELP AT THE LANDING?

WE'VE GOT



THIS.

POWER. SPEED. EFFICIENCY.

John Deere knuckleboom loaders have always been some of the most rugged machines in the forest. The 337E and 437E are no exception. Designed to deliver maximum productivity and uptime, and low daily operating costs, they are among the most powerful, reliable, and efficient machines in their class — and in any neck of the woods.

RUGGED RELIABILITY

Load warriors.

Day after day, tough 337E and 437E Knuckleboom Loaders stand up to punishing logging environments, to keep you going strong all day, every day.

Optimized hydraulic oil reservoir capacity

Hydraulic oil reservoir has been decreased from 80 to 45 gallons, reducing refill time and oil-change costs.

Powerful engines

Our EPA Final Tier 4 (FT4) diesel engines employ technologies that are simple to use and deliver the best combination of performance, efficiency, and reliability to your operation — and your bottom line.

Auto-idle

Automatically reduce engine speed when hydraulics aren't in use with the auto-idle feature, saving precious fuel.

Low total fluid consumption

John Deere FT4 engines maintain maximum engine performance while minimizing total fluid consumption — diesel fuel plus diesel exhaust fluid.

Maximize uptime

Large fuel tanks, reliable cylinders, and fuel-sipping diesels enable you to work longer between fill-ups. Plus, hydraulic options on the 437E allow you to power a circle saw or self-propelled carrier, helping you further maximize uptime and productivity.

Better fuel economy

Operating rpm has been optimized to improve fuel efficiency by more than five percent, on average, without loss of machine performance.



STRONG SWING TORQUE AND LIFT FORCE

Load more wood.

To stay ahead of the competition, you need to keep up at the landing. Our 337E and 437E Knuckleboom Loaders set the pace.





Smart hydraulics

Proven pressure-compensated load-sensing hydraulic system on both models delivers power on demand for strong delimiting performance while reducing fuel consumption.

More power to the cut

Circle saw's dedicated pump increases cutting power and saw-recovery time, and supports the requirements of all circle saw sizes and applications.

Efficient swing system

Dedicated swing circuit provides the power needed for noticeably productive delimiting and loading.

GO QUIETLY ABOUT YOUR BUSINESS

This roomy cab isn't shy about its many attributes.

Comfortable operators are productive operators. These machines offer lots of features to keep you nice and cool, especially for work in warmer environments.

Quiet comes standard

The noise the operator experiences in the seat of the standard cab is 35-percent lower than the sound-pressure level within earlier models.

Hearing is believing

New cell-phone holder enables hands-free talk. Premium speakers let the Bluetooth® radio come in clear.

Cool by design

A ventilated cooling/heated seat and an in-cab storage cooler are welcome options on long workdays.

Easy-to-read monitor

Conveniently located monitor displays essential machine information, including fuel usage and engine diagnostic data such as oil and coolant status.

Light things up

New LED lighting options, including two lights on the machine upper frame, help illuminate delimiting tasks.

No sweat

Rear and left back windows have been replaced with heat-deflecting sheet metal to keep the sun's rays from scorching your back and neck. Improved HVAC system with enhanced ventilation delivers more stable cab interior temperatures than previous models.

Take your seat

Large doorway allows easy entry and exit. Fully adjustable seat provides daylong comfort. "Large windows help bring the outside into close range.

At your command

Single right-hand joystick control enables a full range of travel and jib functions, for effortless, ergonomic machine proficiency.



ENHANCED VENTILATION



HELPS KEEP OPERATOR COMFORTABLE

MANEUVERABLE GRAPPLES

Get a nimble grip.

Deere 52-inch log grapple, featured on the 437E, smoothly and quickly lifts and holds loads, for improved performance in plantation and second-thinning applications. Deere 48-inch log grapple is available for the 337E. Both attachments are durably cast-steel constructed for impact and wear resistance.

The ability to do more

With more robust rotator pull-through for delimiting applications, as well as maximum torque of 36,200 inch-pound, volume of 0.23 cord per eight-foot wood, and weight of 1,925 pounds, the Deere 52-inch log grapple confidently grabs, lifts, and tackles whatever the forest throws its way.

Master and command

Vehicle hydraulics on the 52-inch log grapple are tuned to the rotator, for more precise operator control. Steady lifting capacity, powerful swing torque, and sure hold of chip-and-saw-size loads are reliably within easy reach.

Proven performer

The 337E comes factory equipped with the Deere 48-inch log grapple. Ample opening-width range of four to 48 inches enables faster loading of trucks and delimiting of large first-thinning bundles.

Hydraulics for attachments

Deere 437E and 337E Knuckleboom Loaders come factory equipped with a complete hydraulic package to help you get even more work done. Dedicated hydraulic routings with improved retention ease installation. A smaller hydraulic tank helps make regular changes and refills more manageable.





UP
TO **52-in.**
OPENING
ON 437E GRAPPLE

Ground-level oil drain and filter change

Quick, easy access to hydraulic components helps reduce the cost of hydraulic oil and filter changes. An electric hydraulic oil-refill pump is an available option.

Remote diagnostics

When your machine is equipped with JDLink™, remote diagnostics, rapid service response with the right part in hand, parts availability, and dealer support are always within easy reach.

Keep it clean

High-debris grille option is available to help keep debris from entering the coolers, for increased uptime.

Quick and simple serviceability

Hinged-panel doors provide fast access to service points, so daily checks get done with little fuss.

Convenient maintenance basics

Stable lower platform enables open access to daily checkpoints, hoses, and periodic service items, for trouble-free maintenance.

Wide-open access to cooling package

Efficient fan and other cooling system components swing out for convenient cleaning.

Save fuel

Pressure-compensated load-sensing saw circuit works in tandem with a dedicated saw pump to maximize fuel efficiency.



LESS UPKEEP,

Visualize more productivity with
**TIMBERMATIC™ MAPS
AND TIMBERMANAGER™**

TimberMatic* Maps and TimberManager* are proven jobsite-mapping tools designed for full-tree logging operations. TimberMatic Maps enables enhanced visibility, allowing operators to review production values as well as see and create points of interest that can be shared in real time with other onsite team members. Staff not on the jobsite can also access any of this data through TimberManager, to optimize tasks and increase efficiency.

*Not all options are offered in all areas.

Get valuable insight with
**JOHN DEERE
FORESTSIGHT™**

The in-base JDLink™ telematics subscription is the foundation of our John Deere ForestSight forestry technology solutions. To optimize productivity and efficiency, TimberMatic Maps helps eliminate guesswork for your operators related to routes and the location of timber. And TimberManager provides complete visibility to your operation — from land harvested to the machines at work — so you can streamline communication and increase efficiency.

With John Deere Connected Support™, dealer machine monitoring and remote diagnostics and programming capability can quickly identify and diagnose problems that may occur, while machine health alerts developed through analyzing data from the entire population of John Deere machines can help prevent problems altogether.



MORE UPTIME.

337E / 437E

Engine	337E	437E
Manufacturer and Model	John Deere 6068 HTJ57 PowerTech™ PVS	John Deere 6068 HTJ57 PowerTech PVS
Non-Road Emission Standards	EPA Final Tier 4/EU Stage IV	EPA Final Tier 4/EU Stage IV
Cylinders	6	6
Valves per Cylinder	4	4
Displacement	6.8 L (415 cu. in.)	6.8 L (415 cu. in.)
Gross Rated Power	129 kW (173 hp) at 2,000 rpm	129 kW (173 hp) at 2,000 rpm
Net Torque Rise	17%	17%
Net Peak Torque	722 Nm (532 lb.-ft.) at 1,500 rpm	722 Nm (532 lb.-ft.) at 1,500 rpm
Aspiration	Turbocharged, air-to-air aftercooled	Turbocharged, air-to-air aftercooled
Air Cleaner	Dry-type with safety element	Dry-type with safety element
Cooling		
Fan Type	Engine-driven ECU-controlled viscous clutch	Engine-driven ECU-controlled viscous clutch
Hydraulics		
337E/437E		
Main Pump	Tandem variable-displacement, axial-piston, load-sensing system	
Controls	Pilot levers, short stroke, low effort	
Fill System	Hand pump through return filters standard / 12-volt electric-fill pump through return filter optional	
Cylinders		
Heat-treated, chrome-plated, polished cylinder rods; hardened steel (replaceable bushings) pivot pins		
Boom (1)		
Bore	180 mm (7.1 in.)	
Rod Diameter	95 mm (3.7 in.)	
Jib (1)		
Bore	160 mm (6.3 in.)	
Rod Diameter	95 mm (3.7 in.)	
Stabilizers (4)		
Bore	140 mm (5.5 in.)	
Rod Diameter	70 mm (2.8 in.)	
Electrical		
Voltage	12 volt	
Number of Batteries	2	
Battery Capacity		
At -17.8 deg. C (0 deg. F)	950 CCA	
At 0 deg. C (32 deg. F)	1,110 CCA	
Alternator Rating	120 amp	
Lights	Halogen: 2 front standard / Halogen: 2 front, 2 rear, 1 cab right side, 1 cab left side optional	
Boom		
337E		
437E		
Knuckleboom	9.10 m (29 ft. 10 in.)	9.76 m (32 ft. 0 in.)
Swing Mechanism		
Swing Speed	10.0 rpm	10.0 rpm
Drive	2-stage planetary gearbox with piston motor	2-stage planetary gearbox with piston motor
Bearing	Hardened gear, greaseable from cab	Hardened gear, greaseable from cab
Swing Torque	44 038 Nm (32,500 lb.-ft.)	52 032 Nm (38,400 lb.-ft.)
Serviceability		
337E/437E		
Hinged engine side shields; local grease points; hydraulic "O"-ring face-seal connectors; ground-level hydraulic oil and filter change; hydraulic oil electric fill-pump option		
Fluid-Change Intervals		
Engine Oil	500 hours	
Hydraulic Oil	2,000 hours	
Engine Coolant	6,000 hours	
Swing- and Pump-Drive Gearbox Oil (each)	1,000 hours	
Refill Capacities		
Fuel Tank	340 L (90.0 gal.)	
Diesel Exhaust Fluid (DEF) Tank	20 L (5.0 gal.)	
Cooling System	28 L (7.5 gal.)	
Engine Crankcase	20 L (5.3 gal.)	
Hydraulic Tank	170 L (45.0 gal.)	
Swing-Drive Gearbox	5.3 L (1.4 gal.)	
Pump-Drive Gear Case	5 L (1.4 gal.)	
Operating Weight (less attachment)		
337E		
437E		
Includes Standard Equipment, Half-Full Fuel Tank, All Fluids, 80-kg (175 lb.) Operator, and Grapple	13 871 kg (30,580 lb.)	15 909 kg (35,073 lb.)

Specifications are subject to change without notice.



Machine Dimensions	337E	437E
A Tail Swing	395 mm (15.5 in.)	721.3 mm (28 in.)
B Machine Height	4112 mm (13 ft. 6 in.)	4112 mm (13 ft. 6 in.)
C Maximum Stabilizer Reach Below Grade	257 mm (10 in.)	257 mm (10 in.)
D Trailer Height	972 mm (3 ft. 2 in.)	972 mm (3 ft. 2 in.)
E Maximum Trailer Width	883 mm (35 in.)	883 mm (35 in.)
F Transport Width	2606 mm (8 ft. 7 in.)	2606 mm (8 ft. 7 in.)
G Stabilizer Spread at Ground Level	5309 mm (17 ft. 5 in.)	5309 mm (17 ft. 5 in.)
H Overall Lower Frame Length	3810 mm (12 ft. 6 in.)	3810 mm (12 ft. 6 in.)
I Stabilizer Pad Length	533 mm (21 in.)	533 mm (21 in.)
J Boom Reach	9144 mm (30 ft. 0 in.)	9754 mm (32 ft. 0 in.)
K Stabilizer Pad Width	889 mm (35 in.)	889 mm (35 in.)

337E Knuckleboom Loader

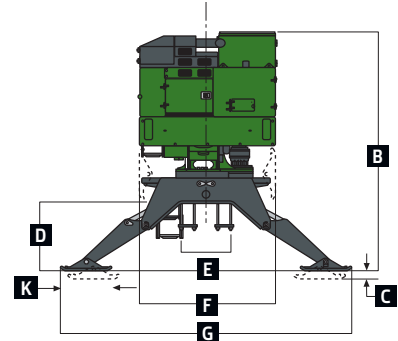
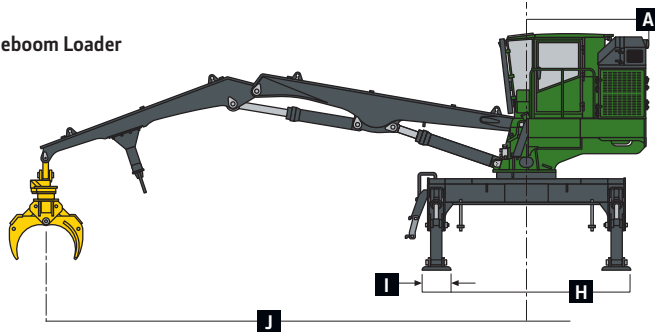

437E Knuckleboom Loader

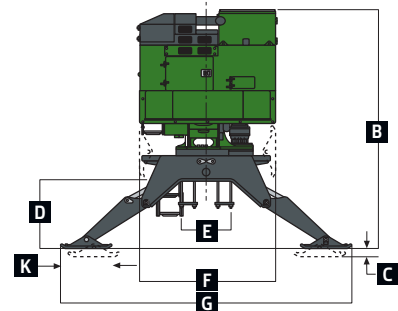
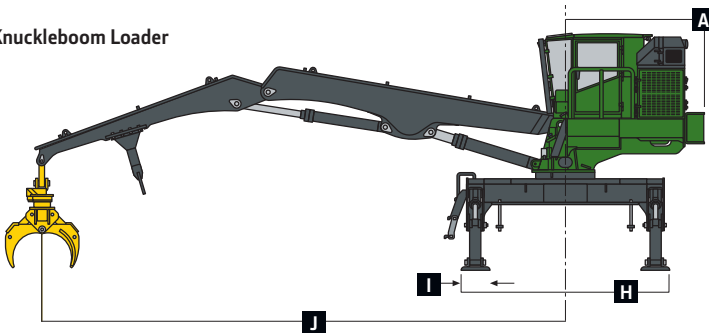

Lift Capacity — 337E (no heel, bare pin)

Load Point Height	Reach — Horizontal from Centerline of Rotation				Maximum Weight at Maximum Distance
	3.1 m (10 ft.)	4.6 m (15 ft.)	6.1 m (20 ft.)	7.6 m (25 ft.)	
Lifting Over Front					
6.1 m (20 ft.)		4770 kg (10,516 lb.)	4380 kg (9,656 lb.)	4030 kg (8,885 lb.)	1930 kg (4,255 lb.) at 8.5 m (28.0 ft.)
4.6 m (15 ft.)		5330 kg (11,751 lb.)	4720 kg (10,406 lb.)	4140 kg (9,127 lb.)	2050 kg (4,519 lb.) at 8.9 m (29.3 ft.)
3.1 m (10 ft.)	8980 kg (19,798 lb.)	6610 kg (14,573 lb.)	5160 kg (11,376 lb.)	4290 kg (9,458 lb.)	1895 kg (4,178 lb.) at 9.2 m (30.0 ft.)
1.5 m (5 ft.)	4070 kg (8,973 lb.)	7430 kg (16,380 lb.)	5500 kg (12,125 lb.)	4360 kg (9,612 lb.)	1563 kg (3,446 lb.) at 9.1 m (29.9 ft.)

Lift Capacity — 437E (no heel, bare pin)

Load Point Height	Reach — Horizontal from Centerline of Rotation					Maximum Weight at Maximum Distance
	3.1 m (10 ft.)	4.6 m (15 ft.)	6.1 m (20 ft.)	7.6 m (25 ft.)	9.1 m (30 ft.)	
Lifting Over Front						
6.1 m (20 ft.)		7660 kg (16,887 lb.)	6850 kg (15,102 lb.)	6220 kg (13,713 lb.)	3910 kg (8,620 lb.)	3675 kg (8,102 lb.) at 9.1 m (29.9 ft.)
4.6 m (15 ft.)		8960 kg (19,753 lb.)	7460 kg (16,446 lb.)	6480 kg (14,286 lb.)	5410 kg (11,927 lb.)	3580 kg (7,893 lb.) at 9.6 m (31.4 ft.)
3.1 m (10 ft.)	8980 kg (19,798 lb.)	10 500 kg (23,149 lb.)	8160 kg (17,990 lb.)	6780 kg (14,947 lb.)	5710 kg (12,588 lb.)	3800 kg (8,378 lb.) at 9.8 m (32.0 ft.)
1.5 m (5 ft.)	6180 kg (13,625 lb.)	11 730 kg (25,860 lb.)	8690 kg (19,158 lb.)	6950 kg (15,322 lb.)	5570 kg (12,280 lb.)	3880 kg (8,554 lb.) at 9.7 m (31.8 ft.)

Log Grapple	4048	4552
Maximum Opening	1219 mm (48 in.)	1328 mm (52.2 in.)
Minimum Opening	102 mm (4 in.)	115 mm (4.5 in.)

Machine not exactly as shown. Illustrations for dimensioning purposes only.



JOHN DEERE

JohnDeere.com/forestry

OUTRUN™

**CUT. DRAG. LOAD.
SUCCESS COMES IN THREES.**

For loggers in the South, efficiency and profit go hand in hand. And nothing drives efficiency like the complete set of solutions only John Deere delivers. Get machines, technology, support, and financing to move your operation forward. With all the pieces in place, you're ready to OUTRUN.