

648L-II SKIDDER



JOHN DEERE



648L-II SKIDDER



RELIABLE WARRIOR IN THE WOODS.

When loggers like you tell us what they need to succeed in the woods and at the landing, we listen and then get to work putting ideas into action. Based on some of your best input, the John Deere 648L-II Skidder boasts a wealth of performance and durability features to keep you running long and strong. Our latest upgrades reflect years of continual refinement that have resulted in a proven machine that's simple to operate, easy to maintain, and reliable to own. The 648L-II is more than ready to help you take on tasks in the real woods.

All about uptime

Simplified routing of the electrical and hydraulic systems helps boost reliability and ease maintenance. Improved protection of wiring and hoses minimizes wear and bending. Electrical components are durably constructed to withstand tough forestry applications and extend wear life.

Best of both worlds

Continuously Variable Transmission (CVT) combines the efficiency of direct drive with the smoothness and operating ease of hydrostatic drive. Automatically sensing the load, CVT delivers torque and tractive effort as needed to maintain the maximum speed the operator sets, reducing engine wear, optimizing fluid economy, and eliminating manual shifting.

Comfortable cushioning

Steering sensors control articulation speed when nearing frame-to-frame contact, cushioning impact during full articulation and enhancing operator comfort.

Speed things up

Two-speed 4000 and 6000 Winches increase line pull and is faster than the single-speed winch on previous models, boosting productivity.



CVT TRANSMISSION
ELIMINATES
MANUAL SHIFTING

Large and in charge

Optional 1.63-square-meter (17.5 square foot) grapple on the 648L-II helps you deliver more wood to the landing with fewer skids. Grapple squeeze provides a constant pressure, so operators are less likely to lose a log, even if a load gets jarred.

Effortless operation

Armrest-mounted electrohydraulic controls provide easy, fingertip operation of all machine functions. Joystick steering provides smooth, intuitive control of steering, direction, and ground speed.

Independent axle-diff lock

Engage the front and rear axles, or just the front or rear as needed, to maneuver over tough terrain.

Stable and capable

Combining impressive horsepower and power-to-weight ratio with a constant engine speed, the 648L-II delivers superb responsiveness with maximum efficiency. Rock-solid stability provides excellent pulling power, especially when climbing hills, navigating adverse terrain, or hauling bigger payloads.

648L-II SKIDDER

***PUT TECHNOLOGY TO WORK
IN THE WOODS AND AT THE OFFICE.***

Coordinate your operation and your team's productivity from wherever your work takes you with John Deere Precision Forestry and our core technology solutions.

FEATURES

Core intelligence

Your John Deere Forestry machine arrives from the factory equipped with a powerful set of technologies and capabilities already built in. Each plays an important role in managing the health and performance of your overall equipment fleet:

- **JDLink™** connectivity lets you track your equipment, see which machines are working, and know if they're being utilized properly and at maximum productivity and efficiency.
- Enabled through JDLink, **John Deere Connected Support** leverages a suite of dealer and factory tools designed to deliver increased uptime and productivity, and lower daily operating costs.
- **Remote Diagnostics and Programming Capability** within John Deere Connected Support helps your dealer warn you of any issue with your machine — often before you know of the problem yourself — and initiate solutions without charging you for a technician's visit to your jobsite.
- Our advanced dual approach to **Machine Health** combines the expertise of the technology specialists at our dealerships with the data specialists at our central Machine Health Monitoring Center (MHMC). As part of John Deere Connected Support, information from thousands of connected machines flows through the MHMC, enabling our specialists to identify trends and develop new and improved preventative-maintenance and repair protocols.

Precision Forestry

Take the guesswork out of planning, implementing, and monitoring your logging operation. The tools of our production-planning and -tracking system expand on the core technology features that come standard in every John Deere Forestry machine to unleash a powerful new array of possibilities:

- **TimberMatic™ Maps** is an innovative onboard software solution that helps you reimagine your jobsites. Real-time production views, optimized routes, and shared wireless connections between machines make it easier than ever before to take your forestry operation to the next level.
- **TimberManager™** is a web-based solution for PCs, tablets, and mobile phones that allows you to follow jobsite progress. Combined with TimberMatic Maps, this software provides complete visibility of your operation — from land harvested to specific machines — so you can streamline communication, analyze tasks, and increase productivity:
 - **Remote Monitoring** keeps tabs on the health and performance of your fleet from wherever you are.
 - **Precise Progress Tracking** lets you set goals for your team to meet throughout the day.
 - **Live Production View** displays progress including tree count, area harvested, and estimated tonnage.
 - **Simplified Mapping** of machine data and GPS-based location tracking shows precise stem and log counts.
 - **Real-Time Updates** let you adjust course or eliminate tasks if needed to maintain steady workflow.
 - **Fleet Optimization** goes beyond machine management to help improve the efficiency of your business.



**JOHN DEERE
CONNECTED SUPPORT™**

CONNECTS YOUR OPERATION
TO DEALER & FACTORY EXPERTISE

648L-II SKIDDER SPECIFICATIONS

Engine		648L-II	
Manufacturer / Model	John Deere PowerTech™ PSS 6.8L	John Deere PowerTech™ Plus 6.8L	John Deere PowerTech™ 6.8L
Off-Road Emission Standards	EPA Final Tier 4/EU Stage V	EPA Tier 3/EU Stage IIIA	EPA Tier 2/EU Stage II
Gross Power	177 kW (237 hp) at 1,800 rpm	163 kW (218 hp) at 1,800 rpm	157 kW (210 hp) at 1,800 rpm
Gross Torque	1025 Nm (756 ft.-lb.) at 1,600 rpm	979 Nm (722 ft.-lb.) at 1,400 rpm	943 Nm (695 ft.-lb.) at 1,400 rpm
Number of Cylinders	6	6	6
Valves per Cylinder	4	4	4
Engine Displacement	6.8 L (415 cu. in.)	6.8 L (415 cu. in.)	6.8 L (415 cu. in.)
Engine Bore and Stroke	106 x 127 mm (4.17 X 5.00 in.)	106 x 127 mm (4.17 X 5.00 in.)	106 x 127 mm (4.17 X 5.00 in.)
Fuel System	High-pressure common rail	High-pressure common rail	High-pressure common rail
Aspiration	Turbocharged and charge-air cooled	Turbocharged and charge-air cooled	Turbocharged and charge-air cooled
Air Cleaner	Dual stage with safety element	Dual stage with safety element	Dual stage with safety element
Engine Cold-Start System	Glow plugs	Glow plugs	Glow plugs
Cooling		Heavy-duty radiator with continuous deaeration tank and recovery reservoir	
Cooling System			
Fan Drive	Hydraulic, variable speed, reversing		
Powertrain		Continuously Variable Transmission (CVT)	
Transmission			
Speed Ranges, Forward and Reverse	6		
Maximum Travel Speed With 30.5-32 Tires	0–24.74 km/h (0–15.37 mph) — 6 speed-range configurations available		
Axles	30 deg.		
Front Axle Oscillation, Stop to Stop	Options		
Options	1400 Extreme Duty and 1400 Super-Wide Extreme-Duty (SWEDA™)		
Differential (front and rear)	Hydraulic-locking, operated-on-the-go, closed-center differential lock		
Steering	Fully hydraulic, joystick or wheel		
Articulation Angle	45-deg. each direction		
Service Brakes	Inboard-mounted, wet-disc, oil-cooled, self-adjusting and self-equalizing front and rear axles		
Parking Brake	Automatically spring-applied, hydraulically released, sealed and lubricated, wet multi-disc		
Hydraulics		Open circuit, axial piston, variable displacement	
Main Pump			
Maximum Displacement	85 cc/rev (5.19 ci/rev)		
Electrical System		24 volt	
Voltage			
Number of Batteries (12 volt)	2		
Battery Capacity (each)	950 CCA		
Alternator Rating	150 amp		
Lights (optional)	11		
Dual-Function Grapples		Standard	
Standard			
Opening	3226 mm (127 in.)		
Area	1.24 m ² (13.3 sq. ft.)		
Optional			
Opening	3251 mm (128 in.)		
Area	1.48 m ² (15.9 sq. ft.)		
Optional			
Opening	3886 mm (153 in.)		
Area	1.63 m ² (17.5 sq. ft.)		
Grapple Control	Joystick		
Refill Capacities		Standard	
Fuel Tank			
Standard	391.8 L (103.5 gal.)		
Optional	457.7 L (120.9 gal.)		
Hydraulic Reservoir	123.6 L (32.6 gal.)		
Diesel Exhaust Fluid (DEF) Tank	19.9 L (5.2 gal.)		
Operating Weight		2192 mm (86.3 in.) or 2962.4 mm (116.6 in.)	
Machine Weight			
Dozer Blade		687.6 mm (27.1 in.)	
Width			
Height			
Blade Control	Joystick		

While general information, pictures, and descriptions are provided, some illustrations and text may include product options and accessories NOT AVAILABLE in all regions, and in some countries products and accessories may require modifications or additions to ensure compliance with the local regulations of those countries.

Boom Options		648L-II	
Size	2.6 m (8.5 ft.)		
Winch			
Winch Control	Joystick control, hydraulically driven		
Cable Capacity	2-Speed 6000 Winch With 279.5-mm (11 in.) Drum	2-Speed 4000 Winch With 204-mm (8 in.) Drum	
15.8 mm (5/8 in.)	119.0 m (390 ft.)	77.4 m (252 ft.)	
19.1 mm (3/4 in.)	81.4 m (267 ft.)	54.6 m (177 ft.)	
22.2 mm (7/8 in.)	60.3 m (197 ft.)	39.3 m (128 ft.)	
25.4 mm (1 in.)	46.0 m (150 ft.)	30.7 m (100 ft.)	
Line Pull – 15.8-mm (5/8 in.) Cable	<i>Bare Drum at Stall With 2-Speed 6000 Winch</i>		<i>Bare Drum at Stall With 2-Speed 4000 Winch</i>
Low Speed	221.0 kN (49,696 lb.)		213.5 kN (47,997 lb.)
High Speed	147.3 kN (33,131 lb.)		142.3 kN (31,990 lb.)
Line Speed – 15.8-mm (5/8 in.) Cable	<i>Bare Drum at 1,800 rpm With 2-Speed 6000 or 4000 Winch</i>		
Low Speed	13.4 m/min. (44 fpm)		
High Speed	20.1 m/min. (66 fpm)		
Machine Dimensions			
	<i>Dual Function</i>		
Tire Size	30.5-32		
A Overall Height	3365 mm (132.5 in.)		
B Overall Width	3233 mm (127.3 in.)		
C Maximum Blade Lift Above Ground	1517 mm (59.7 in.)		
D Maximum Blade Dig Below Ground	359 mm (14.1 in.)		
E Dozer Blade Width	2192 mm (86.3 in.)		
Optional Dozer Blade Width	2962.4 mm (116.6 in.)		
F Wheelbase	3680 mm (144.8 in.)		
G Ground Clearance	557 mm (21.9 in.)		
H Overall Length	8129 mm (320.0 in.)*		
*Length based on 2.6-m (8.5 ft.) boom.			

648L-II Skidder With Dual-Function Grapple

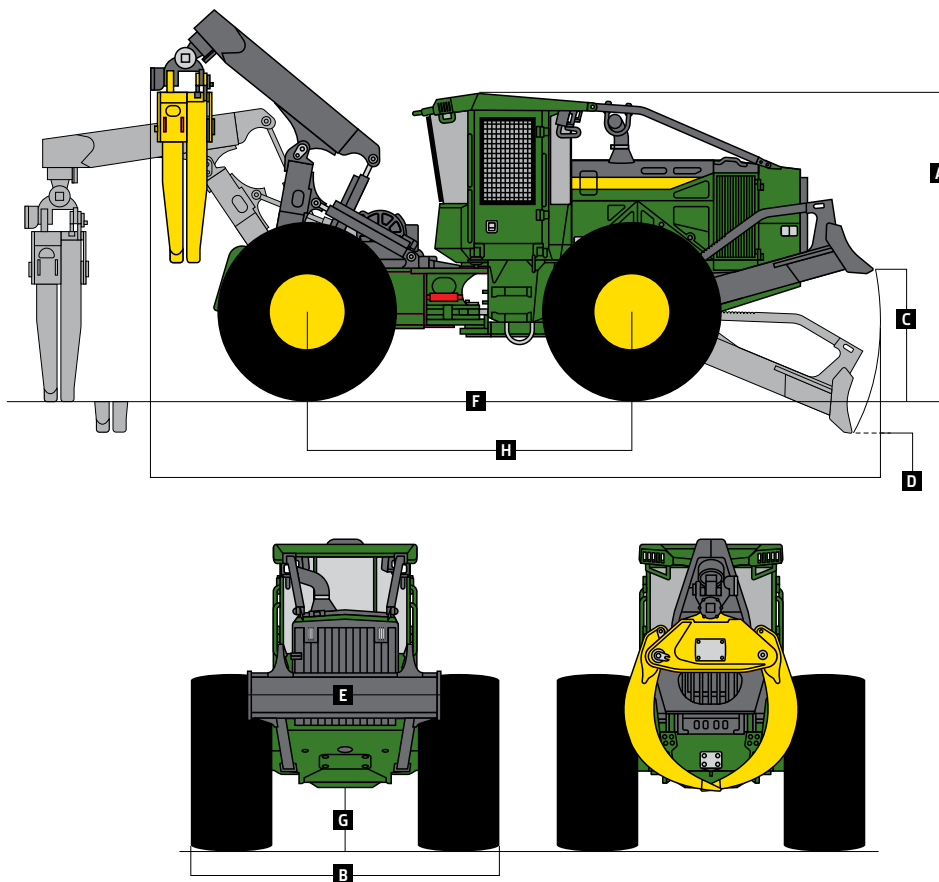

While general information, pictures, and descriptions are provided, some illustrations and text may include product options and accessories NOT AVAILABLE in all regions, and in some countries products and accessories may require modifications or additions to ensure compliance with the local regulations of those countries.



MSK648LIU (22-07)

Contact us to learn more.

JohnDeere.com/Skidders
JohnDeere.ca/Skidders



JOHN DEERE