

# 324L

Compact Wheel Loader



JOHN DEERE





## ***RUN SMALL, DREAM BIG***

Your workday is usually long, your tasks can take you into tight places, and your budget can be just as limited. That's why you need smaller do-it-all equipment that combines head-turning maneuverability, sure-footed stability, and cost-effective capability with productive power, responsive travel speed, and ease of serviceability. Meet the 324L Compact Wheel Loader, designed to include a wide range of reliable standard features and proven options that help this highly adaptable, multipurpose machine deliver the big results that will have you imagining what it can accomplish for your operation.

## Turn things around

Industry-exclusive Articulation Plus™ steering system combines 30 degrees of articulation with 10 additional degrees of rear-wheel steer. Reduced articulation angle design delivers tighter turns that are more stable, especially with large loads, than comparatively sized loaders without Articulation Plus.

## On the level

Loader arm and coupler design improves the lifting path to near parallel — for better load-carrying capability than previous models. This keeps the load more level from ground to truck-bed height and helps the operator focus on the task instead of on making manual adjustments.

## Lift, reach, repeat

With exceptional lift and height to hinge pin, the optional High-Lift configuration makes the 324L especially adept at repetitive dumping and stacking applications.

## Fast getaway

With a standard top speed of over 23 mph, the 324L can make some pretty quick moves on and between jobsites.

## Control and command

Low-effort joystick controls boom and bucket, F-N-R, and differential lock. Standard mini-joystick controls auxiliary hydraulic functions including high flow. Adjustable-height monitor lets operators keep close watch on vital machine functions. Expansive floor-to-ceiling tinted glass provides a commanding view of the work at hand and around the machine.



**MORE  
STABLE\***

+



**MORE  
MANEUVERABLE\***

+



**MORE  
CAPABLE\***

\*Compared to leading competitive articulation loaders of the same size.

### Lighten up

In-cab lighting activates when the door is opened to illuminate machine entrances and exits. Optional LED front and rear work lights brilliantly brighten early morning or after-daylight tasks.

### Smooth moves

Load-sensing AutoShift powertrain technology eliminates productivity-interrupting manual shifts between gear ranges while providing smooth direction changes.

### Quick-change artist

Equip your 324L with an ISO coupler to quickly and easily go from bucket to forks, for maximum lift capacity. Opt for the available John Deere quick-coupler to utilize a wide array of skid-steer-compatible attachments. High-flow electro-hydraulic-controlled auxiliary hydraulics are also available.

### It's a lock

Optional throttle lock and creep control let operators set a slow ground speed while maintaining full engine power to an attachment. It's perfect for work with snow blowers, cold planers, or material/manure scrapers.

### Get a grip

Manual low-speed 100-percent differential lock delivers the ground-gripping tractive effort needed to dive deep into the pile and help heap the bucket. Rimpull control manages power to the wheels, allowing the operator to select the optimal setting to reduce tire and driveline wear.



## 324L COMPACT WHEEL LOADER



**OPTIONAL LED FRONT  
& REAR WORK LIGHTS  
ENHANCE VISIBILITY**

### **Keep your cool**

Redesigned engine compartment and cooling package improve airflow and reduce the amount of debris entering the system compared to previous models. Access to all daily service checks and cooler cores is from ground level.

### **Remote diagnostics and support**

To maximize uptime and lower costs, JDLink™ connectivity provides machine location, utilization data, and alerts to help you maximize productivity and efficiency. JDLink also enables John Deere Connected Support™. Dealers use Expert Alerts based on data from thousands of connected machines to proactively address conditions that may otherwise likely lead to downtime. Your dealer can also monitor machine health and leverage remote diagnostics and programming capability to further diagnose problems and even update machine software without a time-consuming trip to the jobsite.\*

\*Availability varies by region. Options not available in every country.

# 324L WHEEL LOADER SPECIFICATIONS

<b>Engine</b>			
Manufacturer and Model	Yanmar 4TNV98CT	Gross Rated Power at 2,400 rpm (ISO 14396)	54 kW (73 hp)
Non-Road Emission Standard	EPA Final Tier 4 (FT4)	Peak Torque at 1,560 rpm	280 Nm (206 lb.-ft.)
Cylinders	4	Engine Bore and Stroke	98 x 110 mm (3.89 x 4.33 in.)
Valves per Cylinder	4	Lubrication	Pressure system with full-flow spin-on filter
Displacement	3.3 L (203 cu. in.)	Aspiration	Turbocharged
Net Peak Power at 2,400 rpm (SAE J1349 / ISO 9249)	52 kW (71 hp)	Air Cleaner	Dual safety element dry type
<b>Cooling</b>			
Fan	Hydraulically driven, proportionally controlled		
Engine Coolant Rating	-37 deg. C (-34 deg. F)		
<b>Powertrain</b>			
Type	Hydrostatic (HST) with infinitely variable speed control over full range of operating speeds; 2 speed ranges; joystick-mounted F-N-R; acceleration pedal; HST inching pedal, which allows infinitely reduced travel speeds while maintaining full engine rpm and hydraulic flow		
2 Travel Speeds in Forward and Reverse (equipped with 405/70R20 tires)			
Gear 1	18 km/h (11.0 mph)		
Gear 2	38 km/h (23.5 mph)		
<b>Axles</b>	Fixed, 100% differential, manually engaged front axle; fixed, conventional differential rear axle		
Rear Axle Oscillation Versus Front Axle	16 deg. total, stop to stop		
<b>Differentials</b>	Manual (push-button) 100% locking front, conventional rear		
Maximum Rise and Fall, Single Wheel	370 mm (14.5 in.)		
<b>Steering</b>	Hydraulic power steering (SAE J1511); 30-deg. articulation left and right with mechanical-actuated rear-wheel steering		
Steering Wheel Turns, Stop to Stop	4¼ (2 left / 2¼ right)		
Articulation Angle	60-deg. arc (30 deg. each direction)		
<b>Final Drive</b>	Heavy-duty outboard planetary		
<b>Brakes</b> (SAE J1473 / ISO 3450)	Hydraulically actuated, self-adjusting internal wet-disc brake and driveline drum brake		
Service Brakes	Automatically spring-applied, hydraulically released, internal wet disc		
Parking Brake			
<b>Hydraulics</b>			
<b>Main Pump (loader and steering)</b>	Fixed-displacement gear pump; open-center system		
Standard	93 L/m (25 gpm)	<b>Hydraulic Cycle Times</b>	
Total With High-Flow Option	132 L/m (35 gpm)	Raise	5.6 sec.
Maximum Pressure at Couplings	21 000 kPa (3,045 psi)	Dump	2.0 sec.
<b>System Relief Pressure</b>		Lower	4.4 sec.
Loader	18 960 kPa (2,750 psi)	Total	12.0 sec.
Steering	18 000 kPa (2,611 psi)		
<b>Controls</b>	Pilot-operated, 3-function valve with single-lever control for boom and bucket, standard pin disconnect and 3rd-function proportional electrohydraulic (EH) auxiliary hydraulics		
<b>Cylinders</b>			
Type	Heat-treated, chrome-plated, polished cylinder rods; hardened steel (replaceable bushings) pivot pins		
<b>Electrical</b>			
Type	Electrical load center with blade-type multi-fused circuits		
Voltage	12 volt		
Number of Batteries	1		
Battery Capacity	925 CCA		
Alternator Rating	80 amp		
<b>Lights (SAE 99)</b>	Driving/front working lights (2), turn signals, flashers, and stop- and taillights		
<b>Operator Station</b>			
<b>Noise Level</b>			
Operator Ear (ISO 6396)	68 dBA		
Bystander (ISO 6395)	101 dBA		
<b>Tires/Wheels</b>			
<b>Tires on Single-Piece Rims</b>	<i>Tread Width*</i>	<i>Width Over Tires<sup>1</sup></i>	<i>Change in Vertical Height</i>
405/70R18 Firestone Duraforce (standard)	1630 mm (5 ft. 4 in.)	2090 mm (6 ft. 10 in.)	0 mm (0 in.)
405/70R20 Mitas EM-01 (optional)	1630 mm (5 ft. 4 in.)	2090 mm (6 ft. 10 in.)	+27 mm (+1.0 in.)
400/70R20 Michelin Bibload (optional)	1630 mm (5 ft. 4 in.)	2080 mm (6 ft. 10 in.)	+15 mm (+1.0 in.)
400/70R20 Michelin XMCL (optional)	1630 mm (5 ft. 4 in.)	2090 mm (6 ft. 10 in.)	+21 mm (+1.0 in.)
*Also see <b>Q</b> in <b>Dimensions</b> section on pages 7 and 9. / <sup>1</sup> Also see <b>R</b> in <b>Dimensions</b> section on pages 7 and 9.			
<b>Serviceability</b>			
<b>Refill Capacities</b>		<b>Refill Capacities (continued)</b>	
Cooling System (engine and radiator)	12.1 L (12.7 qt.)	Fuel Tank	90 L (23.8 gal.)
Differential and Planetary Axle		Hydraulic/HST Reservoir With Filter	66 L (17.4 gal.)
Front	7.4 L (7.8 qt.)	HST Motor Gearbox	1.7 L (1.8 qt.)
Rear	6.8 L (7.2 qt.)	Front/Rear Axle Planetary Hubs (each)	0.8 L (1.0 qt.)
Engine Oil With Filter	10 L (10.8 qt.)		

While general information, pictures, and descriptions are provided, some illustrations and text may include product options and accessories NOT AVAILABLE in all regions, and in some countries products and accessories may require modifications or additions to ensure compliance with the local regulations of those countries.

**Operating Weights 324L**

With standard equipment, 405/70R20 tires, standard counterweight, cab, 79-kg (175 lb.) operator, and full fuel tank

<b>ISO Quick-Coupler</b>	
With 1.1-m <sup>3</sup> (1.4 cu. yd.) Stockpiling/ General-Purpose Bucket With Bolt-On Edge	6400 kg (14,110 lb.)
With 1.6-m <sup>3</sup> (2.1 cu. yd.) Stockpiling/ General-Purpose Bucket With Bolt-On Edge With Fork	6465 kg (14,253 lb.)
<b>Quik-Tatch™ Quick-Coupler</b>	
With 1.1-m <sup>3</sup> (1.4 cu. yd.) Stockpiling/ General-Purpose Bucket With Bolt-On Edge	6590 kg (14,528 lb.)
With 1.6-m <sup>3</sup> (2.1 cu. yd.) Stockpiling/ General-Purpose Bucket With Bolt-On Edge With Fork	6290 kg (13,867 lb.)
<b>Optional Components</b>	
ISO Quick-Coupler	
0.8-m <sup>3</sup> (1.0 cu. yd.) General-Purpose Bucket With Bolt-On Edge	337 kg (743 lb.)

<b>Optional Components (continued)</b>	
ISO Quick-Coupler (continued)	
1.1-m <sup>3</sup> (1.4 cu. yd.) Stockpiling/General- Purpose Bucket With Bolt-On Edge	457 kg (1,008 lb.)
1.6-m <sup>3</sup> (2.1 cu. yd.) Light-Material Bucket With Bolt-On Cutting Edge	520 kg (1,146 lb.)
Fork Frame and Forks (Class 2)	240 kg (511 lb.)
<b>Quik-Tatch Quick-Coupler</b>	
0.8-m <sup>3</sup> (1.0 cu. yd.) General-Purpose Bucket With Bolt-On Edge	535 kg (1,179 lb.)
1.1-m <sup>3</sup> (1.4 cu. yd.) Stockpiling/General- Purpose Bucket With Bolt-On Edge	645 kg (1,421 lb.)
1.6-m <sup>3</sup> (2.1 cu. yd.) Light-Material Bucket With Bolt-On Cutting Edge	730 kg (1,609 lb.)
Fork Frame and Severe-Duty (SD) Forks (Class 3B)	336 kg (741 lb.)

**Dimensions and Specifications With ISO Quick-Coupler and Bucket**

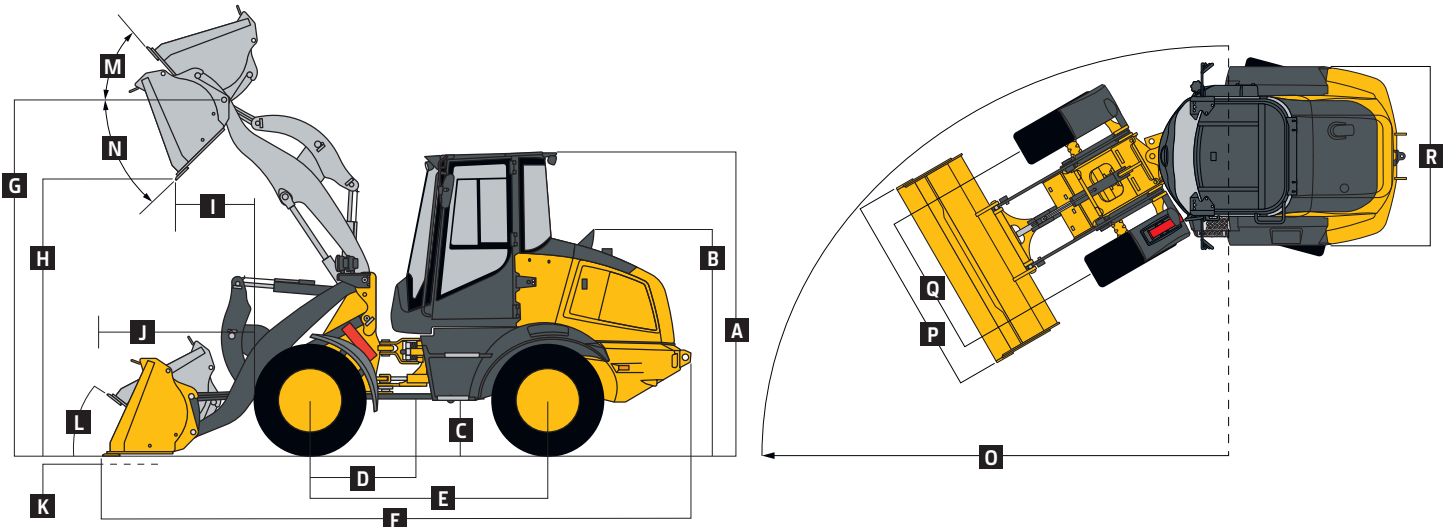

**324L STANDARD-LINKAGE / HIGH-LIFT-LINKAGE LOADERS WITH ISO QUICK-COUPLER AND BUCKET**

	<i>Standard Linkage 1.1-m<sup>3</sup> (1.4 cu. yd.) stock- piling/general-purpose with bolt-on edge</i>	<i>Standard Linkage 1.6-m<sup>3</sup> (2.1 cu. yd.) light-material with bolt-on edge</i>	<i>High-Lift Linkage 0.8-m<sup>3</sup> (1.0 cu. yd.) with bolt-on edge</i>	<i>High-Lift Linkage 1.6-m<sup>3</sup> (2.1 cu. yd.) with bolt-on edge</i>
<b>Dimensions With ISO Quick-Coupler and Bucket</b>				
<b>A</b> Height to Top of Cab	2.78 m (9 ft. 1 in.)	2.78 m (9 ft. 1 in.)	2.78 m (9 ft. 1 in.)	2.78 m (9 ft. 1 in.)
<b>B</b> Height to Top of Exhaust	2.01 m (6 ft. 7 in.)	2.01 m (6 ft. 7 in.)	2.01 m (6 ft. 7 in.)	2.01 m (6 ft. 7 in.)
<b>C</b> Ground Clearance	295 mm (12 in.)	295 mm (12 in.)	295 mm (12 in.)	295 mm (12 in.)
<b>D</b> Length From Centerline to Front Axle	750 mm (30 in.)	750 mm (30 in.)	750 mm (30 in.)	750 mm (30 in.)
<b>E</b> Wheelbase	2.30 m (7 ft. 7 in.)	2.30 m (7 ft. 7 in.)	2.30 m (7 ft. 7 in.)	2.30 m (7 ft. 7 in.)
<b>F</b> Overall Length, Bucket on Ground	5.65 m (18 ft. 6 in.)	5.83 m (19 ft. 1 in.)	6.03 m (19 ft. 9 in.)	6.21 m (20 ft. 4 in.)
<b>G</b> Height to Hinge Pin, Fully Raised	3.35 m (11 ft. 0 in.)	3.35 m (11 ft. 0 in.)	3.79 m (12 ft. 5 in.)	3.79 m (12 ft. 5 in.)
<b>H</b> Dump Clearance, 42-deg. <sup>Δ</sup> Full Height	2.61 m (8 ft. 7 in.)	2.52 m (8 ft. 3 in.)	3.13 m (10 ft. 3 in.)	3.00 m (9 ft. 10 in.)
<b>I</b> Reach, 42-deg. <sup>Δ</sup> Dump, Full Height	920 mm (3 ft. 0 in.)	950 mm (3 ft. 1 in.)	865 mm (34 in.)	934 mm (3 ft. 1 in.)
<b>J</b> Maximum Dump Reach, 42-deg. Dump	1.66 m (5 ft. 5 in.)	1.69 m (5 ft. 6 in.)	1.93 m (6 ft. 4 in.)	2.00 m (6 ft. 7 in.)
<b>K</b> Maximum Digging Depth	90 mm (3.5 in.)	90 mm (3.5 in.)	97 mm (3.8 in.)	97 mm (3.8 in.)
<b>L</b> Maximum Rollback at Ground Level	40 deg.	40 deg.	40 deg.	40 deg.
<b>M</b> Maximum Rollback at Full Height	55 deg.	55 deg.	54 deg.	54 deg.
<b>N</b> Bucket Dump at Full Height	42 deg.	42 deg.	38 deg.	38 deg.
<b>O</b> Turning Circle Radius Over Outside of Bucket Edge	4.14 m (13 ft. 7 in.)	4.28 m (14 ft. 0 in.)	4.21 m (13 ft. 10 in.)	4.49 m (14 ft. 9 in.)
<b>P</b> Bucket Width	2.20 m (7 ft. 3 in.)	2.40 m (7 ft. 10 in.)	1.90 m (6 ft. 3 in.)	2.40 m (7 ft. 10 in.)
<b>Q</b> Tread Width (standard) <sup>§</sup>	1630 mm (5 ft. 4 in.)	1630 mm (5 ft. 4 in.)	1630 mm (5 ft. 4 in.)	1630 mm (5 ft. 4 in.)
<b>R</b> Width Over Tires (standard) <sup>§</sup>	2090 mm (6 ft. 10 in.)	2090 mm (6 ft. 10 in.)	2090 mm (6 ft. 10 in.)	2090 mm (6 ft. 10 in.)
Loader Clearance Circle, Bucket Carry Position	8.28 m (27 ft. 2 in.)	8.55 m (28 ft. 1 in.)	8.42 m (27 ft. 7 in.)	8.98 m (29 ft. 6 in.)

<sup>Δ</sup>38 deg. for High-Lift Linkage.

<sup>§</sup>Also see **Tires/Wheels** section on page 6.

# 324L WHEEL LOADER SPECIFICATIONS (continued)

## Dimensions and Specifications With ISO Quick-Coupler and Bucket (continued)

	324L			
	Standard Linkage	Standard Linkage	High-Lift Linkage	High-Lift Linkage
	1.1-m <sup>3</sup> (1.4 cu. yd.) stock-piling/general-purpose with bolt-on edge	1.6-m <sup>3</sup> (2.1 cu. yd.) light-material with bolt-on edge	0.8-m <sup>3</sup> (1.0 cu. yd.) with bolt-on edge	1.6-m <sup>3</sup> (2.1 cu. yd.) with bolt-on edge
<b>Specifications With ISO Quick-Coupler and Bucket</b>				
Capacity, Heaped (SAE)	1.1 m <sup>3</sup> (1.4 cu. yd.)	1.6 m <sup>3</sup> (2.1 cu. yd.)	0.8 m <sup>3</sup> (1.0 cu. yd.)	1.6 m <sup>3</sup> (2.1 cu. yd.)
Capacity, Struck (SAE)	0.9 m <sup>3</sup> (1.2 cu. yd.)	1.4 m <sup>3</sup> (1.8 cu. yd.)	0.66 m <sup>3</sup> (0.86 cu. yd.)	1.4 m <sup>3</sup> (1.8 cu. yd.)
Breakout Force (SAE J732C)	5650 kg (12,456 lb.)	5180 kg (11,420 lb.)	6000 kg (13,228 lb.)	5160 kg (11,376 lb.)
Tipping Load, Straight	4850 kg (10,692 lb.)	4750 kg (10,472 lb.)	4280 kg (9,436 lb.)	4040 kg (8,907 lb.)
Tipping Load, Full Turn (SAE)	4430 kg (9,766 lb.)	4320 kg (9,524 lb.)	3890 kg (8,576 lb.)	3670 kg (8,091 lb.)
Rated Operating Load, 50% of Full-Turn Tipping Load (conforms to ISO 14397-1)*	2215 kg (4,883 lb.)	2160 kg (4,762 lb.)	1945 kg (4,288 lb.)	1835 kg (4,045 lb.)

\*Rated operating capacity based on Deere attachments only.

## Dimensions and Specifications With ISO Quick-Coupler and Fork

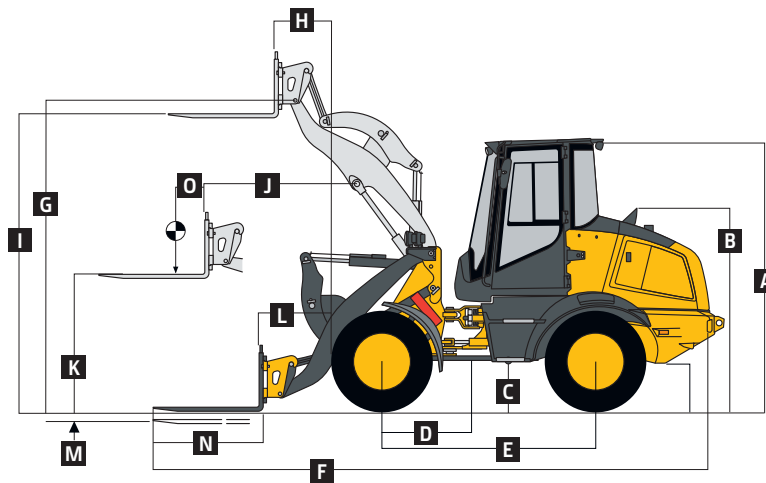

324L STANDARD-LINKAGE / HIGH-LIFT-LINKAGE LOADERS WITH ISO QUICK-COUPLER AND FORK

	Standard Linkage	High-Lift Linkage
<b>Dimensions With ISO Quick-Coupler and Fork</b>	1.20-m (48 in.) tine length	1.20-m (48 in.) tine length
A Height to Top of Cab	2.78 m (9 ft. 1 in.)	2.78 m (9 ft. 1 in.)
B Height to Top of Exhaust	2.01 m (6 ft. 7 in.)	2.01 m (6 ft. 7 in.)
C Ground Clearance	295 mm (12 in.)	295 mm (12 in.)
D Length From Centerline to Front Axle	750 mm (30 in.)	750 mm (30 in.)
E Wheelbase	2.30 m (7 ft. 7 in.)	2.30 m (7 ft. 7 in.)
F Overall Length, Forks on Ground	6.23 m (20 ft. 5 in.)	6.62 m (21 ft. 9 in.)
G Height to Hinge Pin, Fully Raised	3.35 m (11 ft. 0 in.)	3.79 m (12 ft. 5 in.)
H Reach, Fully Raised	570 mm (22 in.)	500 mm (20 in.)
I Fork Height, Fully Raised	3.18 m (10 ft. 5 in.)	3.62 m (11 ft. 10 in.)
J Maximum Reach, Fork Level	1.33 m (4 ft. 4 in.)	1.34 m (4 ft. 5 in.)
K Fork Height, Maximum Reach	1.49 m (4 ft. 11 in.)	1.49 m (4 ft. 11 in.)
L Reach, Ground Level	815 mm (32 in.)	1200 mm (4 ft. 0 in.)
M Depth Below Ground	65 mm (2.6 in.)	85 mm (3.3 in.)
N Tine Length	1.20 m (48 in.)	1.20 m (48 in.)
O Load Position, 50% Tine Length	600 mm (24 in.)	600 mm (24 in.)
<b>Specifications With ISO Quick-Coupler and Fork</b>	<i>As measured with fork level, centered on tine</i>	<i>As measured with fork level, centered on tine</i>
Tipping Load, Straight	3840 kg (8,466 lb.)	3400 kg (7,496 lb.)
Tipping Load, Full Turn (SAE)	3500 kg (7,716 lb.)	3090 kg (6,812 lb.)
Rated Operating Load, 50% Full-Turn Tipping Load (conforms to SAE J1197 / ISO 14397-1)*	1750 kg (3,858 lb.) <sup>†</sup>	1545 kg (3,406 lb.) <sup>†</sup>
Rated Operating Load, Rough Terrain, 60% Full-Turn Tipping Load (conforms to EN474-3)*	2100 kg (4,630 lb.) <sup>†</sup>	1850 kg (4,079 lb.) <sup>†</sup>
Rated Operating Load, Firm and Level Ground, 80% Full-Turn Tipping Load (conforms to EN474-3)*	2500 kg (5,512 lb.) <sup>‡</sup>	2470 kg (5,445 lb.) <sup>†</sup>

\*Rated operating capacity based on Deere attachments only. / <sup>†</sup>Payload on forks is limited by tilt cylinder.

<sup>‡</sup>2,500-kg (5,512 lb.) maximum load capacity for the fork carrier (for standard linkage only).

While general information, pictures, and descriptions are provided, some illustrations and text may include product options and accessories NOT AVAILABLE in all regions, and in some countries products and accessories may require modifications or additions to ensure compliance with the local regulations of those countries.



**Dimensions and Specifications**  
**With Quik-Tatch™ Coupler and Bucket**

324L

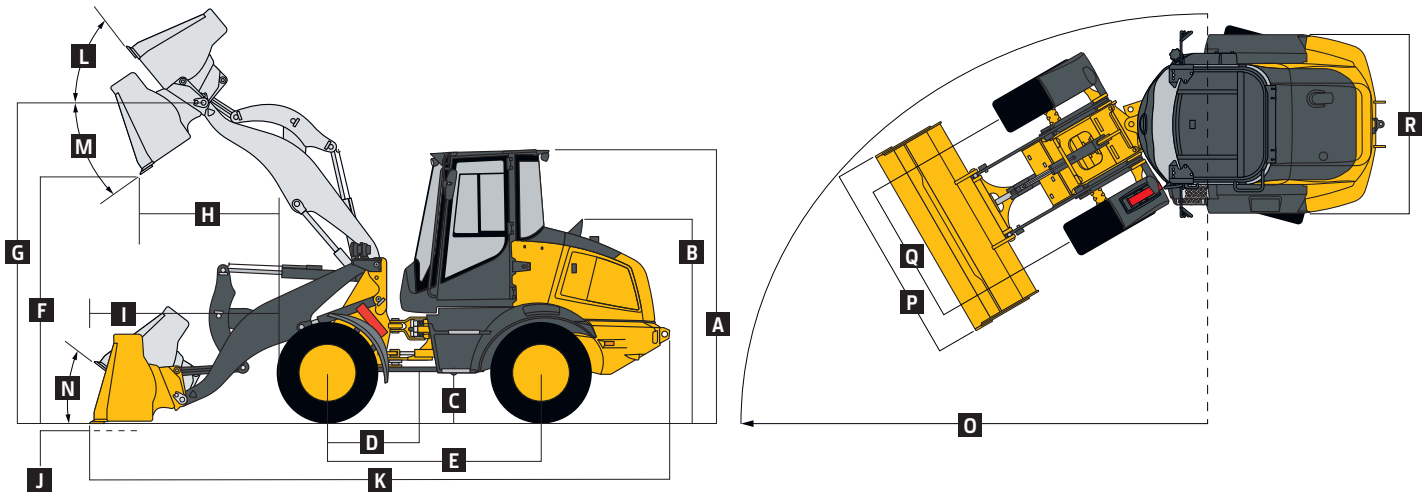

**324L STANDARD-LINKAGE / HIGH-LIFT-LINKAGE LOADERS WITH QUIK-TATCH COUPLER AND BUCKET**

	<i>Standard Linkage</i> 1.1-m <sup>3</sup> (1.4 cu. yd.) stock-piling/general-purpose with bolt-on edge	<i>Standard Linkage</i> 1.6-m <sup>3</sup> (2.1 cu. yd.) light-material with bolt-on edge	<i>High-Lift Linkage</i> 0.8-m <sup>3</sup> (1.0 cu. yd.) stock-piling/general-purpose with bolt-on edge	<i>High-Lift Linkage</i> 1.6-m <sup>3</sup> (2.1 cu. yd.) light-material with bolt-on edge
<b>A</b> Height to Top of Cab	2.78 m (9 ft. 1 in.)	2.78 m (9 ft. 1 in.)	2.78 m (9 ft. 1 in.)	2.78 m (9 ft. 1 in.)
<b>B</b> Height to Top of Exhaust	2.01 m (6 ft. 7 in.)	2.01 m (6 ft. 7 in.)	2.01 m (6 ft. 7 in.)	2.01 m (6 ft. 7 in.)
<b>C</b> Ground Clearance	295 mm (12 in.)	295 mm (12 in.)	295 mm (12 in.)	295 mm (12 in.)
<b>D</b> Length From Centerline to Front Axle	750 mm (30 in.)	750 mm (30 in.)	750 mm (30 in.)	750 mm (30 in.)
<b>E</b> Wheelbase	2.30 m (7 ft. 7 in.)	2.30 m (7 ft. 7 in.)	2.30 m (7 ft. 7 in.)	2.30 m (7 ft. 7 in.)
<b>F</b> Dump Clearance, 40-deg. <sup>Δ</sup> Full Height	2.52 m (8 ft. 3 in.)	2.45 m (8 ft. 0 in.)	3.06 m (10 ft. 0 in.)	2.95 m (9 ft. 8 in.)
<b>G</b> Height to Hinge Pin, Fully Raised	3.35 m (11 ft. 0 in.)	3.35 m (11 ft. 0 in.)	3.79 m (12 ft. 5 in.)	3.79 m (12 ft. 5 in.)
<b>H</b> Reach, 40-deg. <sup>Δ</sup> Dump, Full Height	1.90 m (6 ft. 3 in.)	1.99 m (6 ft. 6 in.)	1.10 m (3 ft. 7 in.)	1.26 m (4 ft. 2 in.)
<b>I</b> Maximum Dump Reach, 42 deg.	1.16 m (3 ft. 10 in.)	1.26 m (4 ft. 1 in.)	2.15 m (7 ft. 1 in.)	2.40 m (7 ft. 10 in.)
<b>J</b> Maximum Digging Depth	69 mm (2.7 in.)	69 mm (2.7 in.)	80 mm (3.1 in.)	80 mm (3.1 in.)
<b>K</b> Overall Length, Bucket on Ground	5.91 m (19 ft. 5 in.)	6.04 m (19 ft. 10 in.)	6.26 m (20 ft. 6 in.)	6.45 m (21 ft. 2 in.)
<b>L</b> Maximum Rollback at Full Height	58 deg.	58 deg.	56 deg.	56 deg.
<b>M</b> Bucket Dump at Full Height	40 deg.	40 deg.	42 deg.	42 deg.
<b>N</b> Maximum Rollback at Ground Level	50 deg.	50 deg.	40 deg.	40 deg.
<b>O</b> Turning Circle Radius Over Outside of Bucket Edge	4.19 m (13 ft. 9 in.)	4.32 m (14 ft. 2 in.)	4.26 m (14 ft. 0 in.)	4.54 m (14 ft. 11 in.)
<b>P</b> Bucket Width	2.20 m (7 ft. 3 in.)	2.40 m (7 ft. 10 in.)	2.20 m (7 ft. 3 in.)	2.40 m (7 ft. 10 in.)
<b>Q</b> Tread Width (standard) <sup>§</sup>	1630 mm (5 ft. 4 in.)	1630 mm (5 ft. 4 in.)	1630 mm (5 ft. 4 in.)	1630 mm (5 ft. 4 in.)
<b>R</b> Width Over Tires (standard) <sup>§</sup>	2090 mm (6 ft. 10 in.)	2090 mm (6 ft. 10 in.)	2090 mm (6 ft. 10 in.)	2090 mm (6 ft. 10 in.)
Loader Clearance Circle, Bucket Carry Position	8.37 m (27 ft. 6 in.)	8.63 m (28 ft. 4 in.)	8.52 m (27 ft. 11 in.)	9.07 m (29 ft. 9 in.)

<sup>Δ</sup>35 deg. for High-Lift Linkage.

<sup>§</sup>Also see **Tires/Wheels** section on page 6.

**Specifications With Quik-Tatch Coupler and Bucket**

Capacity, Heaped (SAE)	1.1 m <sup>3</sup> (1.4 cu. yd.)	1.6 m <sup>3</sup> (2.0 cu. yd.)	0.8 m <sup>3</sup> (1.0 cu. yd.)	1.6 m <sup>3</sup> (2.1 cu. yd.)
Capacity, Struck (SAE)	0.9 m <sup>3</sup> (1.2 cu. yd.)	1.4 m <sup>3</sup> (1.8 cu. yd.)	0.66 m <sup>3</sup> (0.86 cu. yd.)	1.4 m <sup>3</sup> (1.8 cu. yd.)
Breakout Force (SAE J732C)	4590 kg (10,119 lb.)	3875 kg (8,543 lb.)	5100 kg (11,244 lb.)	3960 kg (8,730 lb.)
Tipping Load, Straight	4625 kg (10,196 lb.)	3520 kg (7,760 lb.)	3685 kg (8,124 lb.)	3450 kg (7,606 lb.)
Tipping Load, Full Turn (SAE)	4200 kg (9,259 lb.)	4100 kg (9,039 lb.)	3350 kg (7,385 lb.)	3140 kg (6,923 lb.)
Rated Operating Load, 50% of Full-Turn Tipping Load (conforms to ISO 14397-1)*	2100 kg (4,630 lb.)	2050 kg (4,519 lb.)	1675 kg (3,693 lb.)	1570 kg (3,461 lb.)

\*Rated operating capacity based on Deere attachments only.

# 324L WHEEL LOADER SPECIFICATIONS (continued)

## Dimensions and Specifications With Quik-Tatch Coupler and Fork

324L

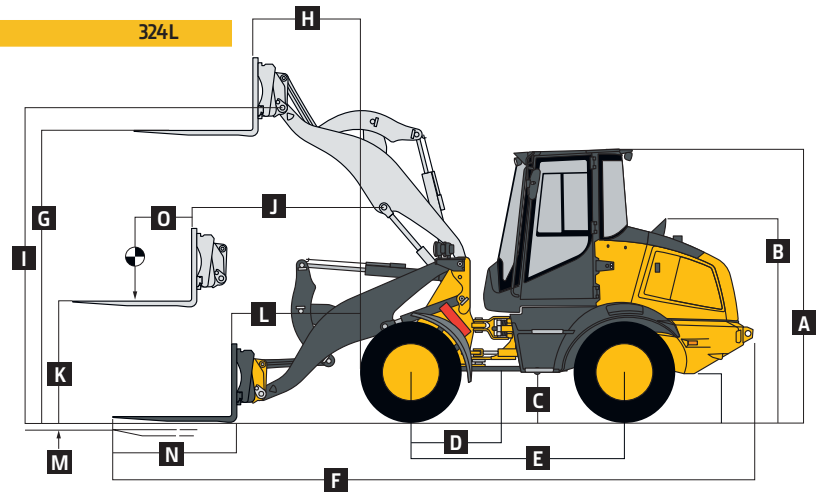

### 324L STANDARD-LINKAGE / HIGH-LIFT-LINKAGE LOADERS WITH QUIK-TATCH COUPLER AND FORK

Dimensions With Quik-Tatch Coupler and Fork	Standard Linkage	High-Lift Linkage
	A Height to Top of Cab	1.20-m (48 in.) tine length
B Height to Top of Exhaust	2.78 m (9 ft. 1 in.)	2.78 m (9 ft. 1 in.)
C Ground Clearance	2.01 m (6 ft. 7 in.)	2.01 m (6 ft. 7 in.)
D Length From Centerline to Front Axle	295 mm (12 in.)	295 mm (12 in.)
E Wheelbase	750 mm (30 in.)	750 mm (30 in.)
F Overall Length, Forks on Ground	2.30 m (7 ft. 7 in.)	2.30 m (7 ft. 7 in.)
G Height to Hinge Pin, Fully Raised	6.30 m (20 ft. 8 in.)	6.66 m (21 ft. 10 in.)
H Reach, Fully Raised	3.35 m (11 ft. 0 in.)	3.79 m (12 ft. 5 in.)
I Fork Height, Fully Raised	615 mm (24 in.)	580 mm (23 in.)
J Maximum Reach, Fork Level	3.15 m (10 ft. 4 in.)	3.59 m (11 ft. 9 in.)
K Fork Height, Maximum Reach	1.37 m (4 ft. 6 in.)	1.70 m (5 ft. 7 in.)
L Reach, Ground Level	1.46 m (4 ft. 9 in.)	1.46 m (4 ft. 9 in.)
M Depth Below Ground	855 mm (34 in.)	1240 mm (4 ft. 1 in.)
N Tine Length	95 mm (4 in.)	110 mm (4.3 in.)
O Load Position, 50% Tine Length	1.20 m (48 in.)	1.20 m (48 in.)
Specifications With Quik-Tatch Coupler and Fork	600 mm (24 in.)	600 mm (24 in.)
Tipping Load, Straight	<i>As measured with fork level, centered on tine</i>	
Tipping Load, Full Turn (SAE)	3690 kg (8,135 lb.)	3250 kg (7,165 lb.)
Rated Operating Load, 50% Full-Turn Tipping Load (conforms to SAE J1197 / ISO 14397-1)*	3350 kg (7,385 lb.)	2960 kg (6,526 lb.)
Rated Operating Load, Rough Terrain, 60% Full-Turn Tipping Load (conforms to EN474-3)*	1675 kg (3,693 lb.) <sup>†</sup>	1480 kg (3,263 lb.) <sup>†</sup>
Rated Operating Load, Firm and Level Ground, 80% Full-Turn Tipping Load (conforms to EN474-3)*	2000 kg (4,409 lb.) <sup>†</sup>	1770 kg (3,902 lb.) <sup>†</sup>
	2500 kg (5,512 lb.) <sup>‡§</sup>	2370 kg (5,225 lb.) <sup>†</sup>

\*Rated operating capacity based on Deere attachments only.

<sup>†</sup>Payload on forks is limited by tilt cylinder.

<sup>‡§</sup>2,500-kg (5,512 lb.) maximum load capacity for the fork carrier (for standard linkage only).

### Bucket Selection Guide

LOOSE MATERIALS	kg/m <sup>3</sup>	lb./cu. yd.	LOOSE MATERIALS	kg/m <sup>3</sup>	lb./cu. yd.
Chips, pulpwood	288	486	Limestone, coarse, sized	1570	2,646
Cinders (coal, ashes, clinkers)	673	1,134	Limestone, mixed sizes	1682	2,835
Clay and gravel, dry	1602	2,700	Limestone, pulverized or crushed	1362	2,295
Clay compact, solid	1746	2,943	Sand, damp	2083	3,510
Clay, dry in lump loose	1009	1,701	Sand, dry	1762	2,970
Clay, excavated in water	1282	2,160	Sand, voids, full of water	2083	3,510
Coal, anthracite, broken, loose	865	1,458	Sandstone, quarried	1314	2,214
Coal, bituminous, moderately wet	801	1,350	Shale, broken crushed	1362	2,295
Earth, common loam, dry	1218	2,052	Slag, Furnace granulated	1955	3,294
Earth, mud, packed	1843	3,105	Stone or gravel, 37.5 to 87.5-mm (1.5 to 3.5 in.) size	1442	2,430
Granite, broken	1538	2,592	Stone or gravel, 18.75-mm (0.75 in.) size	1602	2,700
Gypsum	2275	3,834			

#### Bucket Fill Factors

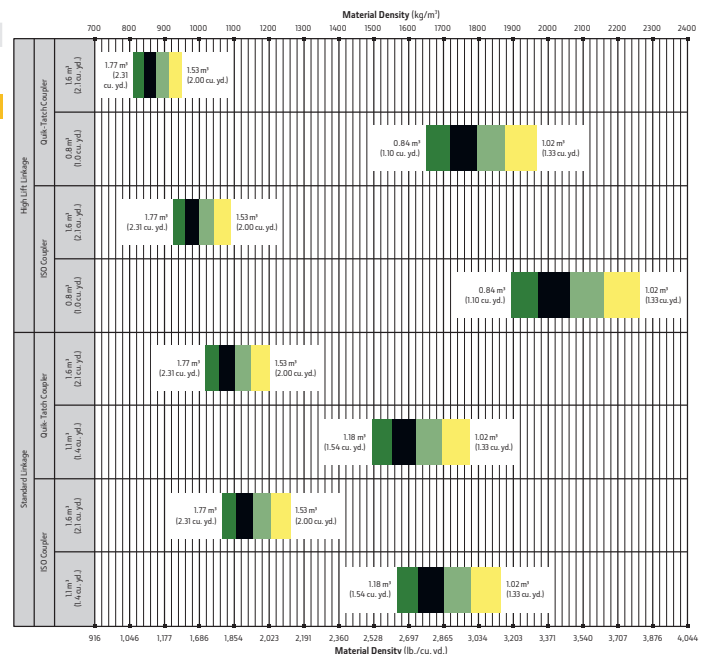
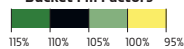

While general information, pictures, and descriptions are provided, some illustrations and text may include product options and accessories NOT AVAILABLE in all regions, and in some countries products and accessories may require modifications or additions to ensure compliance with the local regulations of those countries.

# Additional equipment

Key: ● Standard ▲ Optional or special

See your John Deere dealer for further information.

## 324L Engine

- Antifreeze, -37 deg. C (-34 deg. F)
- Coolant recovery tank
- Fan safety guard
- Fan, suction type, hydraulically driven, proportional speed
- Environmentally friendly engine oil drain
- Spin-on engine oil and fuel filter
- Engine oil cooler
- Quick-release fuel filter and water separator
- Under-hood dual-element air cleaner with restriction indicator with dust-evacuator valve
- Prescreened air intake
- Automatic glow plugs for cold start
- ▲ Engine coolant heater, 110 volts

## Electrical

- Starter switch with electric fuel cutoff
- 12-volt system
- Electrical load center with blade-type fuses behind operator's seat
- Standard 925-CCA battery
- Master electrical disconnect switch
- Alternator, 12 volts, 80 amps
- Horn (conforms to SAE J994 / J1446)
- Lights (conform to SAE 99): Driving / Front working (2) / Turn signals / Flashers / Stop / Taillights
- Worklights, rear (2)
- Reverse warning alarm (conforms to SAE J994 / J1446)
- Multifunction monitor with audible and visual warnings: Low engine oil pressure, engine coolant temperature, hydraulic oil temperature warning light, and parking brake indicator / Gauge and indicator: Engine coolant temperature gauge, fuel level gauge, speedometer, clock, and hour meter
- Indicator lights: Engine air filter / Parking brake actuated / Forward/reverse travel / 1st- or 2nd-speed range / Turn signal and hazard lights / High-beam driving lights indicator / Battery voltage
- Pre-wired for roof beacon

## Powertrain/Brakes

- Smooth AutoShift technology up to 38 km/h (23 mph)

## 324L Powertrain/Brakes (continued)

- Hydrostatic (HST) transmission: Electric shift control / Single-lever joystick F-N-R / HST oil cooler / Inching pedal / 2 speeds forward and reverse / Infinitely variable speed control
- Rimpull control
- Service brakes, hydraulically actuated, self-adjusting internal wet-disc brake and driveline drum brake
- Parking brake, spring applied, hydraulically released, switch operated
- Conventional-type rear differentials, 100% locking front differential

## Hydraulic System

- Hydraulic fan for demand-based cooling
- Hydraulic system oil cooler
- Automatic bucket return-to-dig control
- Boom float detent
- Reservoir sight gauge for hydraulic/HST oil
- Fine-micron hydraulic filters, vertical mounting
- Hydraulic function lockout
- 3-function hydraulic valve with pilot joystick control including auxiliary electrohydraulic (EH) proportional control for 3rd function
- ▲ 132-L/m (35 gpm) high-flow option
- Quick-coupler diagnostic ports: Priority pressure / Hydraulic pump pressure / Control valve pressure / HST pressure

## Operator's Station

- Cab (conforms to SAE J1040, SAE J231, ISO 3471, and ISO 3449): ROPS/FOPS / Heater/defroster / Rubber-plane isolation mounted for noise/vibration reduction / Intermittent front and rear windshield wipers and washers / Tinted safety glass / Adjustable sun visor / Mid-back cloth seat with mechanical suspension / 51-mm (2 in.) retractable seat belt / Full swing-out left and right doors with sliding window in left door
- ▲ Premium air-ride high-back heated seat with headrest and dual lumbar control
- Radio-ready cab, fused 12-volt radio electrical lead and speakers, and power port
- ▲ AM/FM/Weather-Band (WB) radio

## 324L Operator's Station (continued)

- Air conditioning
- Storage compartment for operator's manual and other items located under operator seat and 2 options left of operator seat
- Rubber floor mat
- Dual tilt and telescoping steering column
- Rearview mirrors, outside (2) and inside (1) (conform to SAE J985)
- Handholds and steps, ergonomically located and slip resistant (conform to SAE J185)
- ▲ 76-mm (3 in.) retractable seat belt

## Loader Linkage

- Z-Bar loader linkage provides high bucket breakout
- ▲ High-Lift linkage
- Loader boom service locking bar (conforms to SAE J38)

## Buckets and Attachments

- ▲ Full line of buckets with bolt-on cutting edges
- ▲ ISO-style quick-coupler
- ▲ Quik-Tatch™ coupler
- ▲ Pallet forks
- ▲ Full line of construction utility forks, pallet forks, and other John Deere attachments\*

## Tires

- ▲ 400/70R20 Michelin Bibload
- ▲ 400/70R20 Michelin XMCL
- 405/70R18 Firestone Duraforce
- ▲ 405/70R20 Mitas EM-01

## Other

- ▲ LED worklights (spot or flood)
- ▲ Hydraulic reversing fan
- ▲ Front window guard
- Fenders, front and rear
- Articulation locking bar (conforms to SAE J276)
- Vandal protection, includes lockable engine enclosure and fuel fill
- Cast rear counterweight
- Drawbar, with locking pin
- Lift eyes
- Tie-downs
- ▲ Fire extinguisher
- ▲ Material-weighing system†
- ▲ Ride control

\*See your John Deere dealer for further information.

†Contact LOAD-RITE™.

While general information, pictures, and descriptions are provided, some illustrations and text may include product options and accessories NOT AVAILABLE in all regions, and in some countries products and accessories may require modifications or additions to ensure compliance with the local regulations of those countries.

Net engine power is with standard equipment including air cleaner, exhaust system, alternator, and cooling fan, at standard conditions per SAE J1349 and DIN 70 020, using No. 2-D fuel at 35 API gravity. No derating is required up to 1500-m (5,000 ft.) altitude. Gross power is without cooling fan. Specifications and design subject to change without notice. Wherever applicable, specifications are in accordance with SAE standards. Except where otherwise noted, these specifications are based on a unit with all standard equipment, ROPS cab, 405/70R18 tires, full fuel tank, air conditioning off, and 79-kg (175 lb.) operator.



DKA324LDR (22-10)



**JOHN DEERE**