

844 P

Wheel Loader



JOHN DEERE



PRIMED FOR PRODUCTIVITY



AVS ON THE G5 DISPLAY



SMARTDETECT ON THE G5 DISPLAY

VISION AND DETECTION SYSTEM OFFERINGS

Active jobsites present many operational challenges, including multiple machines, crew members, and bystanders. The John Deere Advanced Vision System (AVS) and SmartDetect™ can help enhance operator awareness to confidently navigate busy work areas:

- Optional **AVS** includes two digital cameras mounted on the rearview-mirror platforms that integrate with the rearview (backup) camera for a single display on a dedicated in-cab monitor.
- Paired with a high-resolution camera and a dedicated display, optional **Advanced Rear Object-Detection System (ARODS)** utilizes a radar system that provides audible alerts when objects are detected at the rear of the machine. ARODS helps operators visualize the loader's reversal path based on its articulation.
- Now available as an easily installed field kit, optional **SmartDetect** alerts operators of objects entering the machine's projected travel path, emitting sound and visual alerts inside the cab as well as an audible alarm to detected bystanders. SmartDetect requires AVS, ARODS, and a G5 display as well as software activation.

LARGE AND IN CHARGE

READY TO DO THE HEAVY LIFTING.

Combining serious performance with fuel efficiency, customer-inspired components, and intuitive controls, our 844 P-Tier provides the muscle operators need to work productively and comfortably. Enhancements include increased horsepower, an ergonomically reimagined cab, and simplified service points. With its rugged EPA Final Tier 4/EU Stage V-compliant John Deere JD14 engine, high-capacity heavy-duty axles, and a wealth of proven options, this large-scale wheel loader is built rock solid for the long haul.

Step up your game

With standard advantages such as a reliable JD14 engine with in-line aftertreatment, fuel-efficient lockup torque converter, and high-strength steel buckets, the 844 P-Tier can heap heavier and haul more.

Outsized comfort

Cab boasts three more inches of legroom than previous models. Standard premium heated/ventilated seat, updated HVAC system with automatic temperature control, and redesigned sealed-switch module are placed for ergonomic comfort and convenience. A wider door than on previous series models makes getting in and out easier.

It's easy to take control

Easier and more intuitive to operate than the controls on previous models, seat-mounted right-hand hydraulic controls feature two programmable multifunction buttons with electro-hydraulic (EH) controls.

Material matters

SmartWeigh option features dynamic weighing technology that allows operators to weigh without interrupting workflow and removes the need to lower and raise the boom after tipoff. Shared through the onboard monitor, SmartWeigh is easy to calibrate and effortlessly integrates with the John Deere Operations Center™ so you can track and visualize payload data from almost anywhere. Available as a factory-installed or field-kit option, you can also try SmartWeigh at a low cost for 250 machine hours.

Connected machines

John Deere construction equipment comes with in-base connectivity — free from subscriptions or annual renewals. Analyze critical machine data, track utilization, review diagnostic alerts, and more from **the John Deere Operations Center.** The Operations Center also enables John Deere Connected Support™, which uses data from thousands of connected machines to proactively address issues before they arise. With your approval, your dealer can also remotely monitor machine health, diagnose problems, and even update machine software without a trip to the jobsite.*

*Availability varies by region and product. Options not available in every country.



SMARTWEIGH™
PAYLOAD-WEIGHING SOLUTION
IS DEERE DESIGNED & SUPPORTED



844 P

WHEEL LOADER



**COOLING SYSTEM
ACCESS IS EASY &
AT GROUND LEVEL**



YOU THOUGHT OF EVERYTHING

IT'S IN THE DETAILS.

Your best ideas have helped our large wheel loaders stand out on the jobsite and in the industry. These are just some of the purpose-built details that add up to push our 844 P-Tier — and your operation — to the next level.



Make the shift

Smooth-shifting transmission delivers impressive acceleration and cycle times. Improved design over earlier models optimizes power and fuel efficiency during transport, roading, and ramp climbing.



Heavy-duty durability

Large, high-capacity, heavy-duty axles with standard axle cooling and filtration increase durability in demanding conditions compared to previous models.



Reliable redesign

Routing of the electrical and hydraulic systems has been significantly simplified to minimize friction, improving reliability and easing maintenance.



Road and go

Versatile log-handler and pipe-handler configurations deliver up to 15-percent-more full-turn tipping-load capacity than the 844K.



Cool where it counts

Stacked cooling package enables direct airflow, to minimize debris buildup. Simply open the rear door at ground level to maintain the fan when needed.



On the winning side

All daily service points including fuel are conveniently grouped on the left side of the machine. Standard auto-lube system saves maintenance time and hassle.



While general information, pictures, and descriptions are provided, some illustrations and text may include product options and accessories NOT AVAILABLE in all regions, and in some countries products and accessories may require modifications or additions to ensure compliance with the local regulations of those countries.

Engine		844 P-TIER STANDARD-LIFT	
Manufacturer and Model	John Deere JD14	John Deere JD14	
Non-Road Emission Standard	EPA Final Tier 4 (FT4)/EU Stage V	EPA Tier 3/EU Stage IIIA	
Cylinders	6	6	
Valves per Cylinder	4	4	
Displacement	13.55 L (827 cu. in.)	13.55 L (827 cu. in.)	
Net Peak Power (ISO 9249)	311 kW (417 hp) at 1,400 rpm	311 kW (417 hp) at 1,400 rpm	
Net Peak Torque (ISO 9249)	2119 Nm (1,563 lb.-ft.) at 1,400 rpm	2119 Nm (1,563 lb.-ft.) at 1,400 rpm	
Net Torque Rise	44%	44%	
Fuel System	Electronic High-Pressure Common Rail (HPCR)	Electronic HPCR	
Lubrication	Full-flow spin-on filter and integral cooler	Full-flow spin-on filter and integral cooler	
Aspiration	Single turbocharged, charge air cooled	Single turbocharged, charge air cooled	
Air Cleaner	Dual-element dry type, restriction indicator in cab monitor for service; additional centrifugal engine pre-cleaner		
Cooling		EPA FT4/EU Stage V / EPA Tier 3/EU Stage IIIA	
Fan Drive	Hydraulically driven, proportionally controlled, fan aft of coolers; automatic reversing fan drive		
Electrical			
Electrical System	24 volt with 145-amp alternator		
Batteries (2 – 12 volt)	1,400 CCA (each)		
Transmission System			
Type	Countershaft-type PowerShift™ with lockup torque converter		
Torque Converter	Single stage, dual phase with freewheeling stator with lockup clutch		
Shift Control	Electronically modulated, adaptive, load and speed dependent		
Operator Interface	Steering-column or joystick-mounted F-N-R and gear-select lever; Quick-Shift button on hydraulic lever		
Shift Modes	Manual/auto (1st–5th or 2nd–5th); Quick-Shift button with 2 selectable modes: kick-down or kick-up/down; and 4 settings for clutch cutoff		
Maximum Travel Speeds (with 875/65R29 L3 tires)	<i>Standard 5-Speed With Lockup Torque Converter</i>		
	<i>Forward</i>	<i>Reverse</i>	
Range 1	6.5 km/h (4.0 mph)	6.4 km/h (4.0 mph)	
Range 2	11.4 km/h (7.1 mph)	11.4 km/h (7.1 mph)	
Range 3	17.4 km/h (10.8 mph)	24.9 km/h (15.5 mph)	
Range 4	24.8 km/h (15.4 mph)	N/A	
Range 5	40.0 km/h (24.9 mph)	N/A	
Axles/Brakes			
Final Drives	Heavy-duty mid-board planetary		
Differentials	Conventional differential front and rear – standard; hydraulic locking front with conventional rear – optional; dual locking front and rear – optional		
Rear Axle Oscillation, Stop to Stop			
With 29.5 R 25, 1 Star L3 Tires	26 deg. (13 deg. each direction)		
With 875/65R29 L3 Tires	16 deg. (8 deg. each direction)		
Brakes (conform to ISO 3450)			
Service	Outboard, forced oil cooled, multi disc		
Parking	Automatic spring applied, hydraulically released, sealed wet multi disc		
Tires/Wheels			
<i>(see page 9 for complete tire adjustments)</i>			
	<i>Tread Width</i>	<i>Width Over Tires</i>	
Michelin 875/65R29, 1 Star L-3	2440 mm (96.1 in.)	3408 mm (134.2 in.)	
Serviceability			
Refill Capacities		Refill Capacities (continued)	
Fuel Tank (with ground-level fueling)	534 L (141 gal.)	Transmission Reservoir With Vertical Filter	28 L (29.5 qt.)
Diesel Exhaust Fluid (DEF) (EPA FT4/EU Stage V only)	26.3 L (6.9 gal.)	Axle Oil (front and rear, each)	68 L (72 qt.)
Cooling System	60.5 L (16 gal.)	Hydraulic Reservoir and Filter	181.7 L (48 gal.)
Engine Oil With Vertical Spin-On Filter	61 L (64.4 qt.)	Park Brake Oil (wet disc)	0.7 L (24 oz.)
Hydraulic System/Steering			
Loader Pumps	2 variable-displacement, load-sensing axial-piston pumps; closed-center system		
Maximum Rated Flow at 6895 kPa (1,000 psi) at 2,000 rpm	570 L/m (150.5 gpm)		
System Relief Pressure	24 900 kPa (3,611 psi)		
Steering Pump	1 variable-displacement, load-sensing axial-piston pump; closed-center system		
Maximum Rated Flow at 6895 kPa (1,000 psi) at 2,000 rpm	199.5 L/m (52.7 gpm)		
System Relief Pressure	24 900 kPa (3,611 psi)		

While general information, pictures, and descriptions are provided, some illustrations and text may include product options and accessories NOT AVAILABLE in all regions, and in some countries products and accessories may require modifications or additions to ensure compliance with the local regulations of those countries.

Hydraulic System/Steering (continued) 844 P-TIER STANDARD-LIFT

EPA FT4/EU Stage V / EPA Tier 3/EU Stage IIIA

Loader Controls	2-function valve; single- or dual-lever controls; control lever lockout feature; optional 3rd-function valve with auxiliary levers
Steering (conforms to ISO 5010)	
Type	Power, fully hydraulic; single-lever control and adjustable wristrest with conventional steering wheel override
Articulation Angle	80-deg. arc (40 deg. each direction)
Turning Radius (measured to centerline of outside tire)	6.30 m (20 ft. 8 in.)
Hydraulic Cycle Times	Standard-Lift
Raise	5.9 sec.
Dump	1.9 sec.
Lower (float down)	3.6 sec.
Total	11.4 sec.

Dimensions and Specifications With Pin-On Bucket

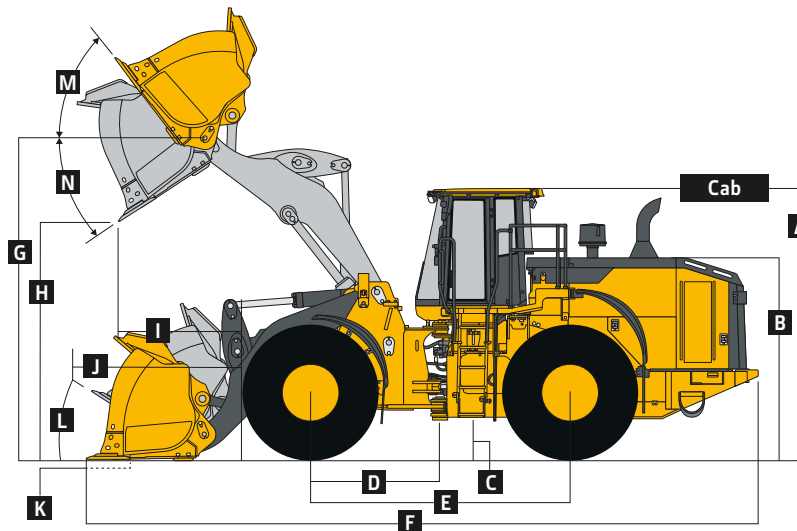

844 P-TIER STANDARD-LIFT WHEEL LOADER WITH PIN-ON BUCKET

Dimensions With Bucket	5.7-m ³ (7.5 cu. yd.) enhanced performance with wear liners bolt-on edge	6.1-m ³ (8.0 cu. yd.) enhanced performance with wear liners bolt-on edge	4.8-m ³ (6.3 cu. yd.) spade-nose rock with wear liners teeth and segments
A Height to Top of Cab	3.73 m (12 ft. 3 in.)	3.73 m (12 ft. 3 in.)	3.73 m (12 ft. 3 in.)
B Hood Height	2.74 m (9 ft. 0 in.)	2.74 m (9 ft. 0 in.)	2.74 m (9 ft. 0 in.)
C Ground Clearance	463 mm (18.2 in.)	463 mm (18.2 in.)	463 mm (18.2 in.)
D Length From Centerline to Front Axle	1.85 m (6 ft. 1 in.)	1.85 m (6 ft. 1 in.)	1.85 m (6 ft. 1 in.)
E Wheelbase	3.70 m (12 ft. 2 in.)	3.70 m (12 ft. 2 in.)	3.70 m (12 ft. 2 in.)
F Overall Length, Bucket on Ground	9.79 m (32 ft. 1 in.)	9.86 m (32 ft. 4 in.)	10.17 m (33 ft. 4 in.)
G Height to Hinge Pin, Fully Raised	4.60 m (15 ft. 1 in.)	4.60 m (15 ft. 1 in.)	4.60 m (15 ft. 1 in.)
H Dump Clearance, 45 deg., Full Height	3.24 m (10 ft. 8 in.)	3.18 m (10 ft. 5 in.)	2.98 m (9 ft. 9 in.)
I Reach, 45-deg. Dump, Full Height	1.52 m (5 ft. 0 in.)	1.57 m (5 ft. 2 in.)	1.80 m (5 ft. 11 in.)
J Reach, 45-deg. Dump, 2.13-m (7 ft. 0 in.) Clearance	2.30 m (7 ft. 7 in.)	2.33 m (7 ft. 8 in.)	2.47 m (8 ft. 1 in.)
K Maximum Digging Depth	111 mm (4.4 in.)	124 mm (4.9 in.)	124 mm (4.9 in.)
L Maximum Rollback at Ground Level	45.3 deg.	45.3 deg.	40.2 deg.
M Maximum Rollback, Boom Fully Raised	59.8 deg.	59.8 deg.	57.4 deg.
N Maximum Bucket Dump Angle, Fully Raised	45.8 deg.	46.2 deg.	46.1 deg.
Loader Clearance Circle, Bucket Carry Position	15.00 m (49 ft. 3 in.)	15.06 m (49 ft. 5 in.)	15.16 m (49 ft. 9 in.)

844 P-TIER

While general information, pictures, and descriptions are provided, some illustrations and text may include product options and accessories NOT AVAILABLE in all regions, and in some countries products and accessories may require modifications or additions to ensure compliance with the local regulations of those countries.

Dimensions and Specifications			
With Pin-On Bucket (continued)			
844 P-TIER STANDARD-LIFT			
EPA Final Tier 4 (FT4)/EU Stage V / EPA Tier 3/EU Stage IIIA			
Specifications With Bucket	5.7-m ³ (7.5 cu. yd.) enhanced performance with wear liners	6.1-m ³ (8.0 cu. yd.) enhanced performance with wear liners	4.8-m ³ (6.3 cu. yd.) spade-nose rock with wear liners
Cutting Edge Type	bolt-on edge	bolt-on edge	teeth and segments
Capacity, Heaped	5.7 m ³ (7.5 cu. yd.)	6.1 m ³ (8.0 cu. yd.)	4.8 m ³ (6.3 cu. yd.)
Capacity, Heaped at 110% Fill Factor	6.3 m ³ (8.25 cu. yd.)	6.7 m ³ (8.8 cu. yd.)	5.3 m ³ (6.9 cu. yd.)
Capacity, Struck	4.7 m ³ (6.2 cu. yd.)	5.0 m ³ (6.6 cu. yd.)	4.1 m ³ (5.4 cu. yd.)
Bucket Weight With Bolt-On Cutting Edge	3181 kg (7,013 lb.)	3222 kg (7,103 lb.)	4240 kg (9,348 lb.)
Bucket Width	3.46 m (11 ft. 4 in.)	3.45 m (11 ft. 4 in.)	3.49 m (11 ft. 6 in.)
Breakout Force	20 287 kg (44,725 lb.)	19 371 kg (42,706 lb.)	16 879 kg (37,212 lb.)
Tipping Load, Straight, No Tire Deflection			
EPA FT4/EU Stage V	23 889 kg (52,666 lb.)	23 709 kg (52,269 lb.)	23 474 kg (51,751 lb.)
EPA Tier 3/EU Stage IIIA	23 531 kg (51,877 lb.)	23 353 kg (51,485 lb.)	23 114 kg (50,958 lb.)
Tipping Load, Straight, With Tire Deflection			
EPA FT4/EU Stage V	21 739 kg (47,926 lb.)	21 576 kg (47,567 lb.)	21 361 kg (47,093 lb.)
EPA Tier 3/EU Stage IIIA	21 413 kg (47,208 lb.)	21 251 kg (46,850 lb.)	21 034 kg (46,372 lb.)
Tipping Load, 37-deg. Partial Turn			
EPA FT4/EU Stage V	21 055 kg (46,418 lb.)	20 892 kg (46,059 lb.)	20 536 kg (45,274 lb.)
EPA Tier 3/EU Stage IIIA	20 740 kg (45,724 lb.)	20 579 kg (45,369 lb.)	20 219 kg (44,575 lb.)
Tipping Load, 40-deg. Full Turn, No Tire Deflection			
EPA FT4/EU Stage V	20 597 kg (45,409 lb.)	20 436 kg (45,064 lb.)	20 060 kg (44,225 lb.)
EPA Tier 3/EU Stage IIIA	20 288 kg (44,727 lb.)	20 130 kg (44,379 lb.)	19 751 kg (43,544 lb.)
Tipping Load, 40-deg. Full Turn, With Tire Deflection			
EPA FT4/EU Stage V	18 743 kg (41,321 lb.)	18 597 kg (40,999 lb.)	18 255 kg (40,245 lb.)
EPA Tier 3/EU Stage IIIA	18 462 kg (40,702 lb.)	18 318 kg (40,384 lb.)	17 973 kg (39,624 lb.)
Rated Operating Load, 50% Full-Turn Tipping Load, With Tire Deflection (conforms to ISO 14397-1)*			
EPA FT4/EU Stage V	9371 kg (20,660 lb.)	9299 kg (20,501 lb.)	9127 kg (20,122 lb.)
EPA Tier 3/EU Stage IIIA	9231 kg (20,351 lb.)	9159 kg (20,192 lb.)	8986 kg (19,811 lb.)
Operating Weight			
EPA FT4/EU Stage V	32 439 kg (71,516 lb.)	32 449 kg (71,538 lb.)	33 851 kg (74,629 lb.)
EPA Tier 3/EU Stage IIIA	32 246 kg (71,090 lb.)	32 257 kg (71,115 lb.)	33 658 kg (74,203 lb.)

Loader operating information is based on machine with identified linkage and standard equipment, John Deere JD14 (EPA FT4/EU Stage V and EPA Tier 3/EU Stage IIIA) engine, ROPS cab, rear cast bumper/counterweight, transmission side-frame guards, bottom guards, standard tires, full fuel tank, and 79-kg (175 lb.) operator. This information is affected by changes in tires, ballast, and different attachments.

*Rated operating capacity based on Deere attachments only.

844 P-TIER LOG HANDLER Dimensions and Specifications With Pin-On Millyard Forks			
Standard-Lift		Standard-Lift	
Dimensions With Millyard Forks	Rockland with 2.13-m (84 in.) tine length	Specifications With Millyard Forks	Rockland with 2.13-m (84 in.) tine length
Height to Top of Cab	3.73 m (12 ft. 3 in.)		EPA Tier 3/ EU Stage IIIA
Hood Height	2.74 m (9 ft. 0 in.)		EPA FT4/EU Stage V
Ground Clearance	463 mm (18.2 in.)	Tipping Load, Straight, No Tire Deflection	19 202 kg (42,333 lb.)
Length From Centerline to Front Axle	1.85 m (6 ft. 1 in.)	Tipping Load, Straight, With Tire Deflection	17 474 kg (38,524 lb.)
Wheelbase	3.70 m (12 ft. 2 in.)	Tipping Load, 37-deg. Partial Turn	16 697 kg (36,811 lb.)
Overall Length, Forks on Ground	10.74 m (35 ft. 3 in.)	Tipping Load, 40-deg. Full Turn, No Tire Deflection	16 292 kg (35,918 lb.)
Height to Hinge Pin, Fully Raised	4.60 m (15 ft. 1 in.)	Tipping Load, 40-deg. Full Turn, With Tire Deflection	14 826 kg (32,686 lb.)
Reach, Fully Raised	0.93 m (3 ft. 1 in.)	Operating Weight	36 795 kg (81,119 lb.)
Fork Height, Fully Raised	4.27 m (14 ft. 0 in.)		36 651 kg (80,802 lb.)
Maximum Reach, Fork Level	1.93 m (6 ft. 4 in.)	Loader operating information is based on machine with identified linkage and standard equipment, John Deere JD14 (EPA FT4/EU Stage V and EPA Tier 3/EU Stage IIIA) engine, ROPS cab, rear cast bumper/counterweight, transmission side-frame guards, bottom guards, standard tires, full fuel tank, and 79-kg (175 lb.) operator. This information is affected by changes in tires, ballast, and different attachments.	
Fork Height, Maximum Reach	1.93 m (6 ft. 4 in.)		
Reach, Ground Level	1.32 m (4 ft. 4 in.)		
Depth Below Ground	160 mm (6.3 in.)		
Tine Length	2.13 m (84 in.)		
Grapple Weight	4468 kg (9,850 lb.)		
Overall Grapple Width	2.74 m (108 in.) (9 ft. 0 in.)		

While general information, pictures, and descriptions are provided, some illustrations and text may include product options and accessories NOT AVAILABLE in all regions, and in some countries products and accessories may require modifications or additions to ensure compliance with the local regulations of those countries.

844 P-TIER

844 P-TIER PIPE HANDLER Dimensions and Specifications With Pin-On Pipe Grapple

Standard-Lift		Standard-Lift	
Rockland with 0.10-m x 0.25-m x 2.44-m (4 in. x 10 in. x 96 in.) tine size		Rockland with 0.10-m x 0.25-m x 2.44-m (4 in. x 10 in. x 96 in.) tine size	
Dimensions With Pipe Grapple		Specifications With Pipe Grapple	
Height to Top of Cab	3.73 m (12 ft. 3 in.)		EPA Tier 3/ EPA FT4/EU Stage V EU Stage IIIA
Hood Height	2.74 m (9 ft. 0 in.)	Tipping Load, Straight, No Tire Deflection	17 114 kg (37,730 lb.) 16 960 kg (37,390 lb.)
Ground Clearance	463 mm (18.2 in.)	Tipping Load, Straight, With Tire Deflection	15 574 kg (34,335 lb.) 15 434 kg (34,026 lb.)
Length From Centerline to Front Axle	1.85 m (6 ft. 1 in.)	Tipping Load, 37-deg. Partial Turn	14 909 kg (32,869 lb.) 14 773 kg (32,569 lb.)
Wheelbase	3.70 m (12 ft. 2 in.)	Tipping Load, 40-deg. Full Turn, No Tire Deflection	14 552 kg (32,082 lb.) 14 419 kg (31,788 lb.)
Overall Length, Forks on Ground	11.04 m (36 ft. 3 in.)	Tipping Load, 40-deg. Full Turn, With Tire Deflection	13 242 kg (29,194 lb.) 13 121 kg (28,927 lb.)
Height to Hinge Pin, Fully Raised	4.60 m (15 ft. 1 in.)	Operating Weight	36 250 kg (79,918 lb.) 36,107 kg (79,602 lb.)
Reach, Fully Raised	0.93 m (3 ft. 1 in.)	<i>Loader operating information is based on machine with identified linkage and standard equipment, John Deere JD14 (EPA FT4/EU Stage V and EPA Tier 3/EU Stage IIIA) engine, ROPS cab, rear cast bumper/counterweight, transmission side-frame guards, bottom guards, standard tires, full fuel tank, and 79-kg (175 lb.) operator. This information is affected by changes in tires, ballast, and different attachments.</i>	
Fork Height, Fully Raised	4.40 m (14 ft. 5 in.)		
Maximum Reach, Fork Level	1.93 m (6 ft. 4 in.)		
Fork Height, Maximum Reach	2.06 m (6 ft. 9 in.)		
Reach, Ground Level	1.22 m (4 ft. 0 in.)		
Depth Below Ground	34 mm (1.3 in.)		
Tine Length	2.44 m (96 in.)		
Grapple Weight	3924 kg (8,651 lb.)		
Overall Grapple Width	3.05 m (120 in.) (10 ft. 0 in.)		

844 P-TIER STANDARD-LIFT Adjustments to Operating Weights and Tipping Loads With Buckets

Adjustments to operating weights, tipping loads, and tires are based on Standard-Lift machine with pin-on 5.7-m³ (7.5 cu. yd.) enhanced-performance bucket with wear liners and bolt-on cutting edge, ROPS cab, rear cast bumper/counterweight, transmission side-frame guards, bottom guards, standard tires, full fuel tank, and 79-kg (175 lb.) operator*

Add (+) or deduct (-) kg (lb.) as indicated for loaders with 3-piece rims	Tipping Load, 37-deg.						
	Operating Weight	Tipping Load, Straight	Partial Turn	Full Turn	Tread Width	Width Over Tires	Vertical Height
Michelin 875/65R29, 1 Star L-3 ^s	+518 kg (+1,142 lb.)	+385 kg (+850 lb.)	+347 kg (+764 lb.)	+340 kg (+750 lb.)	0 mm (0 in.)	+132 mm (+5.2 in.)	+4 mm (+0.16 in.)
Bridgestone 875/65R29, 1 Star L-3 ^s	+798 kg (+1,759 lb.)	+594 kg (+1,309 lb.)	+534 kg (+1,177 lb.)	+524 kg (+1,156 lb.)	0 mm (0 in.)	+100 mm (+3.9 in.)	+2 mm (+0.06 in.)
Michelin 29.5 R 25, 2 Star L-3	0 kg (0 lb.)	0 kg (0 lb.)	0 kg (0 lb.)	0 kg (0 lb.)	0 mm (0 in.)	0 mm (0 in.)	0 mm (0 in.)
Titan 29.5 R 25, 1 Star L-3	+60 kg (+132 lb.)	+45 kg (+98 lb.)	+40 kg (+88 lb.)	+39 kg (+87 lb.)	0 mm (0 in.)	0 mm (0 in.)	-3 mm (-0.12 in.)
Bridgestone 29.5 R 25, 1 Star L-3	+116 kg (+256 lb.)	+86 kg (+190 lb.)	+78 kg (+171 lb.)	+76 kg (+168 lb.)	0 mm (0 in.)	+12 mm (+0.5 in.)	+2 mm (+0.08 in.)
Firestone 29.5-25, 28-Ply L-3	+492 kg (+1,085 lb.)	+366 kg (+807 lb.)	+329 kg (+726 lb.)	+323 kg (+713 lb.)	0 mm (0 in.)	+20 mm (+0.8 in.)	-6 mm (-0.24 in.)
Bridgestone 29.5 R 25, 1 Star L-5 ^s	+1352 kg (+2,981 lb.)	+1006 kg (+2,217 lb.)	+905 kg (+1,994 lb.)	+888 kg (+1,958 lb.)	0 mm (0 in.)	+16 mm (+0.6 in.)	+32 mm (+1.26 in.)
Michelin 29.5 R 25, 1 Star L-5 ^s	+808 kg (+1,781 lb.)	+601 kg (+1,325 lb.)	+541 kg (+1,192 lb.)	+531 kg (+1,170 lb.)	0 mm (0 in.)	+12 mm (+0.5 in.)	+19 mm (+0.75 in.)
5.7-m ³ (7.5 cu. yd.) Enhanced-Performance Bucket Without Wear Liners	-212 kg (-467 lb.)	+227 kg (+500 lb.)	+227 kg (+500 lb.)	+227 kg (+500 lb.)	N/A	N/A	N/A
6.1-m ³ (8.0 cu. yd.) Enhanced-Performance Bucket Without Wear Liners	-240 kg (-529 lb.)	+268 kg (+591 lb.)	+268 kg (+591 lb.)	+268 kg (+591 lb.)	N/A	N/A	N/A

*May change based on vehicle configuration, weight, or tire-pressure adjustments.

^sRequires 8-deg. rear axle stops.

Bucket Selection Guides

LOOSE MATERIALS	kg/m ³	lb./cu. yd.	LOOSE MATERIALS	kg/m ³	lb./cu. yd.
Chips, pulpwood	288	486	Limestone, coarse, sized	1570	2,646
Cinders (coal, ashes, clinkers)	673	1,134	Limestone, mixed sizes	1682	2,835
Clay and gravel, dry	1602	2,700	Limestone, pulverized or crushed	1362	2,295
Clay, compact, solid	1746	2,943	Sand, damp	2083	3,510
Clay, dry in lump loose	1009	1,701	Sand, dry	1762	2,970
Clay, excavated in water	1282	2,160	Sand, voids, full of water	2083	3,510
Coal, anthracite, broken, loose	865	1,458	Sandstone, quarried	1314	2,214
Coal, bituminous, moderately wet	801	1,350	Shale, broken crushed	1362	2,295
Earth, common loam, dry	1218	2,052	Slag, furnace granulated	1955	3,294
Earth, mud, packed	1843	3,105	Stone or gravel, 37.5 to 87.5-mm (1.5 to 3.5 in.) size	1442	2,430
Granite, broken	1538	2,592	Stone or gravel, 18.75-mm (0.75 in.) size	1602	2,700
Gypsum	2275	3,834			

Bucket Fill Factors

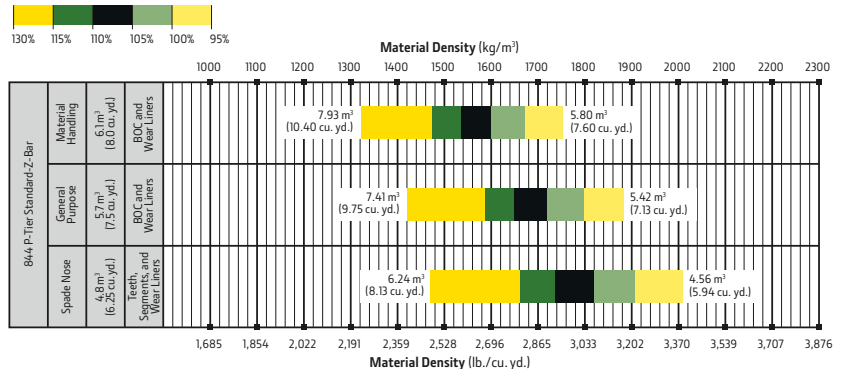

Additional equipment

Key: ● Standard ▲ Optional or special

See your John Deere dealer for further information.

844 P Engine

- Wet-sleeve cylinder liners
- Programmable auto-idle and auto shutdown
- Selected idle adjustment from 900–1,250 rpm
- Starter excessive-cranking protection
- Automatic engine cool-down timer
- Automatic derating for exceeded system temperatures
- Serpentine drive belt for automatic tensioner
- Electrical fuel-priming pump
- Dual-stage fuel filter and water separator
- 500-hour vertical spin-on oil filter
- Engine-compartment light
- Black exhaust stack with brushed-nickel trim
- ▲ Chrome exhaust stack
- ▲ Automatic ether starting aid and engine block heater (recommended for cold starts below –12 deg. C [10 deg. F])
- Centrifugal engine air pre-cleaner
- ▲ Throttle lock

Powertrain

- Clutch cutoff with 4 operator settings: Automatic, level ground, small slope, or steep slope
- Programmable maximum high gear
- Clutch calibration engaged from monitor
- 2,000-hour vertical spin-on transmission filter
- Transmission fill tube with sight gauge
- Transmission diagnostic ports
- 5-speed transmission with lockup torque converter
- ▲ Front locking differential
- ▲ Rear locking differential
- Brake adjusters and retractors
- ▲ Automatic differential lock
- Axle oil temperature sensing
- Wheel-spin control

844 P Quad-Cool™ Cooling System

- Heavy-duty, trash-resistant radiator and high-ambient cooling package
- 2-side access to all coolers
- Isolated from engine compartment
- Engine radiator
- Integral engine oil cooler
- Hydraulic oil cooler (oil to air)
- Transmission oil cooler (oil to air)
- Charge air cooler (air to air)
- Fuel cooler
- Coolant recovery tank with under-hood lighting
- Coolant-loss sensor
- Antifreeze, –37 deg. C (–34 deg. F)
- Cool-on-demand swing-out fan
- Enclosed fan safety guard
- Automatic reversing fan drive
- Axle and service-brake coolers

Hydraulics

- Electrohydraulic control with soft stops and adjustable settings
- In-cab adjustable automatic return-to-dig bucket positioner
- In-cab adjustable automatic boom-height kickout/return to carry
- Reservoir with sight gauge and fill strainer
- Hydraulic diagnostic ports
- 4,000-hour in-tank filter
- 2 function – 2-lever fingertip controls
- ▲ 2 function – joystick
- ▲ 2 function – joystick with F-N-R (steering wheel only)
- ▲ 3 function – 3-lever fingertip controls
- ▲ 3 function – joystick with integrated 3rd-function roller
- ▲ 3 function – joystick with integrated 3rd-function roller and F-N-R (steering wheel only)
- 2 programmable multifunction buttons
- Adjustable and continuous auxiliary hydraulic-flow settings
- Programmable attachment settings

844 P Hydraulics (continued)

- Ride control, automatic with monitor-adjustable speed settings
- ▲ Hydra™ XR cold-temperature hydraulic fluid recommended below –25 deg. C (–13 deg. F)

Steering Systems

- Joystick steering with gearshift, F-N-R, and horn
- ▲ Conventional steering wheel with spinner knob
- ▲ Secondary steering

Electrical

- Solid-state electrical power-distribution system
- Lockable master electrical-disconnect switch
- Battery-terminal safety covers
- By-pass start safety cover at starter
- Remote jump-start access in battery box
- Pre-wired for beacon/strobe light
- ▲ Beacon bracket (single or dual available)
- ▲ LED strobe beacon
- Lights: LED driving lights with guards (2) / Front (4), rear cab (2), and rear grille (2) work lights / LED front turn signals and flashers / LED stop- and taillights
- ▲ Premium LED work, drive, and marker lights
- Programmable courtesy lights
- Horn, electric
- Reverse warning alarm
- Multifunction/multi-language 178-mm (7 in.) LCD color monitor includes: Digital instruments – Analog display (hydraulic oil temperature, engine coolant temperature, transmission oil temperature, and engine oil pressure) / Digital display (engine rpm, transmission gear/direction indicator, hour meter, fuel level, diesel exhaust fluid [DEF] level (EPA Final Tier 4/EU Stage V only), speedometer, odometer, and average fuel consumption)

While general information, pictures, and descriptions are provided, some illustrations and text may include product options and accessories NOT AVAILABLE in all regions, and in some countries products and accessories may require modifications or additions to ensure compliance with the local regulations of those countries.

Net engine power is with standard equipment including air cleaner, exhaust system, alternator, and cooling fan at test conditions per ISO 9249. No derating is required up to 3050-m (10,000 ft.) altitude. Specifications and design subject to change without notice. Specifications with the exception of bucket capacity are in accordance with all applicable ISO standards. Except where otherwise noted, these specifications are based on a unit with applicable linkage and standard equipment, ROPS cab, rear cast bumper/counterweight, transmission side-frame guards, bottom guards, standard tires, full fuel tank, and 79-kg (175 lb.) operator.

Additional equipment *(continued)*

Key: ● Standard ▲ Optional or special

See your John Deere dealer for further information.

844 P Electrical *(continued)*

- Integrated cycle counter with 5 categories
- Indicator lights: Standard and selected options / Amber caution and red stop
- Operator-warning messages
- Built-in diagnostics: Diagnostic-code details / Sensor values / Calibrations / Individual circuit tester
- ▲ Electrical corrosion-prevention package
- Premium AM/FM/Weather Band (WB) radio with Bluetooth®, remote auxiliary port, and remote USB port
- 24- to 12-volt, 30-amp converter with 3 in-cab power ports

Operator's Station

- Quiet Cab with air conditioning/heater (ROPS/FOPS Level 2, isolation mounted)
- Automatic temperature control
- Rear window defrost vent
- Keyless start with multiple security modes
- Sealed-switch module with function indicators
- Premium seat with high-wide back and headrest extension, heated and ventilated, leather/fabric cover, pan tilt/extend, damper adjustments, and adjustable heavy-duty air suspension
- Hydraulic controls and joystick steering integrated to seat
- High-visibility, bright-orange seat belt, 76 mm (3 in.), with retractor
- ▲ 4-point seat-belt harness
- Seat-belt minder monitoring with JDLink™
- ▲ Seat-belt indicator beacon light
- Cup holder and cup/thermos holder with retaining strap
- Lunch-box/cooler holder with tie-down brackets
- LED dome and reading light
- Coat hook
- ▲ Rubber floor mat
- ▲ Dual-tilt steering column (steering wheel only)

844 P Operator's Station *(continued)*

- Operator's manual storage compartment
- Outside (2) and inside (2) rearview mirrors
- ▲ In-cab adjustable heated outside mirrors with convex lens
- Left-side operator-station access
- Front window-washing platforms with fall-arrest system anchor points tested to 2268 kg (5,000 lb.)
- Slip-resistant steps and ergonomic handholds
- Pull-down front sun visor
- ▲ Pull-down rear sun visor
- CB radio ready with 12-volt power, bracket, and antennae included
- Front and rear intermittent windshield wiper and washers
- ▲ Powered cab air pre-cleaner
- Rearview camera
- ▲ Advanced rear object-detection system (EPA FT4/EU Stage V only)
- ▲ Advanced Vision System
- ▲ Rear object-detection system (EPA Tier 3/ EU Stage IIIA only)
- Payload scale ready
- ▲ SmartWeigh™ ready + trial
- ▲ SmartWeigh
- ▲ SmartDetect™
- ▲ Fire extinguisher

Loader Linkage

- Z-Bar loader linkage

Buckets and Attachments

- ▲ Full line of Deere pin-on buckets
- ▲ Bolt-on bucket spill guard
- Bushed pin joints (including static joints) on optional Enhanced-Performance buckets

Overall Vehicle

- JDLink wireless communication system (available in specific countries; see your dealer for details)
- Auto-lube system with empty reservoir sensor and diagnostics integrated into machine diagnostics and JDLink alerts

844 P Overall Vehicle *(continued)*

- Front, mid, and rear tie-downs
- Rear cast bumper with rear hitch and locking pin
- Articulation locking bar
- 40-deg. steering articulation to each side with rubber-cushion stops on frame
- Vandal protection with lockable engine enclosures, right counterweight storage, battery box, and filler access for radiator/fuel/hydraulic transmission
- Right and left handrails, platforms, and steps
- Service steps and handholds
- Storage compartment
- Fuel-tank fill strainer
- Heavy-duty fuel-tank guard
- Ground-level fueling and DEF
- Same-side ground-level daily servicing
- Environmental drains for engine, transmission, hydraulic oils, and engine coolant
- Fluid-sampling ports for engine, transmission, hydraulic and axle oils, and engine coolant
- 29.5R25 tires on 5-piece rims
- ▲ 875/65R29 tires on 5-piece rims
- ▲ Tire-pressure monitoring system
- Level 1 sound package
- Level 2 sound package
- Transmission side-frame and bottom guards
- ▲ Fast-lube system
- ▲ Quick fluid service (engine, transmission, hydraulic oils, and engine coolant)
- Fenders, full-coverage, front
- ▲ Fenders, full-coverage, front and rear
- ▲ Fenders, roading, full-coverage, front and rear
- Lift eyes
- ▲ Wheel-chock-mounting brackets
- ▲ License-plate bracket and light
- ▲ Log handler (Standard-Lift only)
- ▲ Pipe handler (Standard-Lift only)

While general information, pictures, and descriptions are provided, some illustrations and text may include product options and accessories NOT AVAILABLE in all regions, and in some countries products and accessories may require modifications or additions to ensure compliance with the local regulations of those countries.

Net engine power is with standard equipment including air cleaner, exhaust system, alternator, and cooling fan at test conditions per ISO 9249. No derating is required up to 3050-m (10,000 ft.) altitude. Specifications and design subject to change without notice. Specifications with the exception of bucket capacity are in accordance with all applicable ISO standards. Except where otherwise noted, these specifications are based on a unit with applicable linkage and standard equipment, ROPS cab, rear cast bumper/counterweight, transmission side-frame guards, bottom guards, standard tires, full fuel tank, and 79-kg (175 lb.) operator.



MW844PAU (24-09)



JOHN DEERE