

FILTER OVERVIEW WITH SERVICE INTERVALS AND CAPACITIES

6R Series Utility Tractors – 6105R, 6115R and 6125R

ENGINE

SECONDARY AIR FILTER [AL215054](#)

Replace at every fourth change of Primary Air Filter, or after 4500 hours or 5 years, whichever occurs first.

ENGINE

PRIMARY AIR FILTER [AL215055](#)

Replace after every 1500 hours or 2 years, whichever occurs first.

ENGINE

OPEN CRANKCASE VENTILATION (OCV) FILTER

(W/ DIESEL OXIDATION CATALYST) [DZ105796](#)

(W/ DIESEL OXIDATION CATALYST AND DIESEL PARTICULATE FILTER) [DZ105100](#)

Replace after every 1500 hours or 2 years, whichever occurs first.

ENGINE

OIL FILTER [RE504836](#)

Replace after first 100 hours, then after every 500 hours or annually, whichever occurs first.

The extended 500 hour interval is only allowed if using Plus-50™ II oil, JD OEM Oil Filter and diesel fuel with sulfur content less than 15mg/kg (15 ppm).

Change Oil and Filter after every 250 hours, if conditions are not met.

(Click here for [capacity](#))

FRONT PTO

OIL FILTER [DE30500](#)

Replace after every 500 hours.

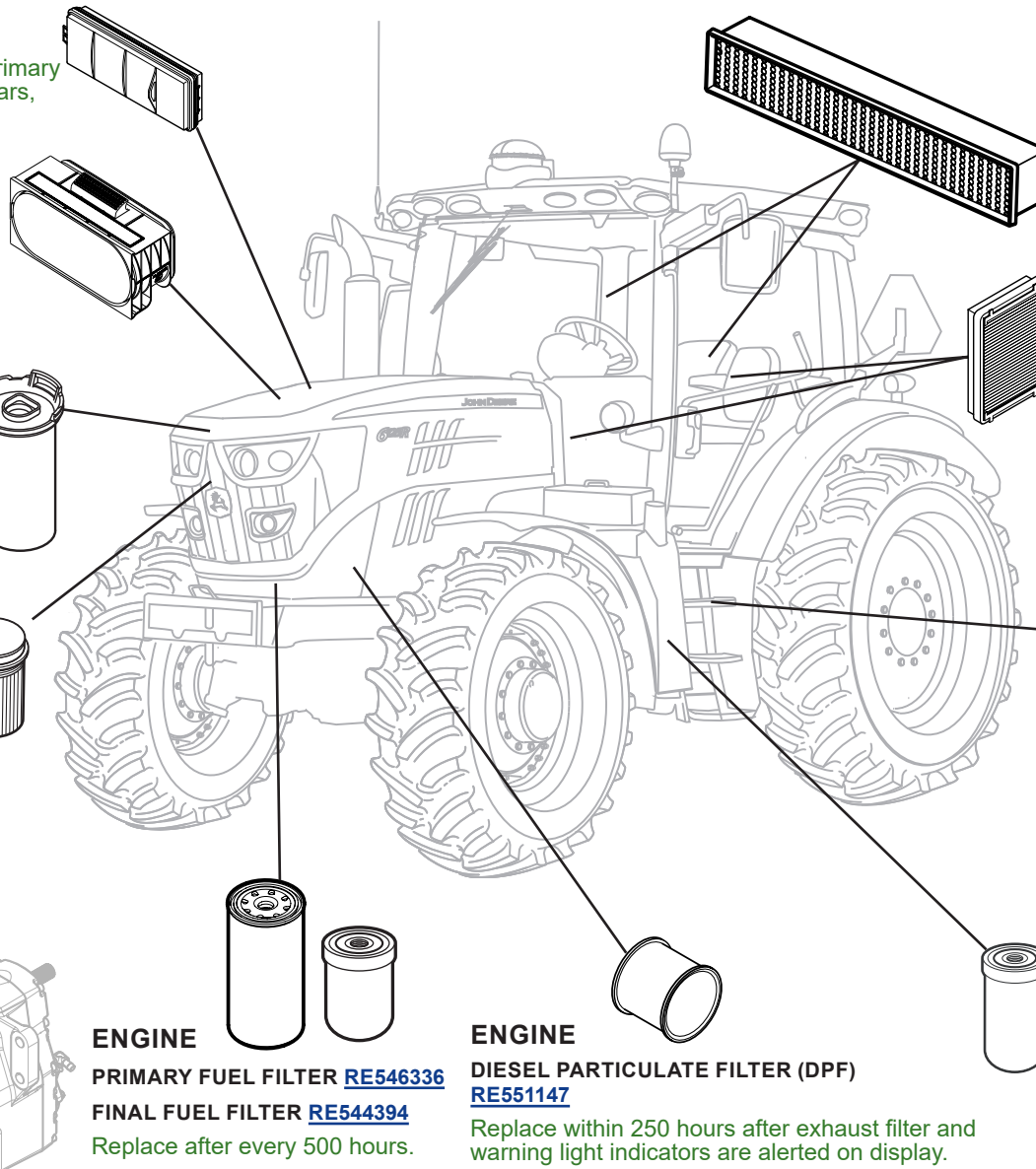

ENGINE

PRIMARY FUEL FILTER [RE546336](#)

FINAL FUEL FILTER [RE544394](#)

Replace after every 500 hours.

ENGINE

DIESEL PARTICULATE FILTER (DPF) [RE551147](#)

Replace within 250 hours after exhaust filter and warning light indicators are alerted on display.

CAB

CAB FRESH AIR FILTER [AL220527](#)

Replace after every 1500 hours, or 2 years, or as required, or with Engine Primary Air Filter, whichever occurs first.

(Activated Carbon Kit) [AL208648](#)

Never clean. Replace after every 500 hours or 1 year or with Engine Primary Air Filter, whichever occurs first. (Interval may vary according to operating conditions.)

CAB

RECIRCULATION AIR FILTER (QTY 2)

W/ AC [L214634](#)

RECIRCULATION AIR FILTER (QTY 2)

W/O AC [L205372](#)

Replace after every 1500 hours, or 2 years, or as required, or with Engine Primary Air Filter, whichever occurs first.

(Activated Carbon Kit) [AL208648](#)

Never clean. Replace after every 500 hours or 1 year or with Engine Primary Air Filter, whichever occurs first.

HYDRAULIC

OIL FILTER [AL169573](#)

Replace after first 100 hours, then after first 750 hours and every 750 hours thereafter. Change Transmission Oil Filter as well.

(Click here for [capacity](#))

TRANSMISSION

OIL FILTER

(AutoPowr™ / IVT™) [AL206482](#)

(Direct Drive W/O IVT™) [AL221066](#)

(PowrQuad™ W/O IVT™) [AL221066](#)

Replace after first 100 hours, then after first 750 hours and every 750 hours thereafter. Change Hydraulic Oil Filter as well.

(Click here for [capacity](#))



JOHN DEERE
Genuine Parts and Service

CAPACITIES

6R Series Utility Tractors – 6105R, 6115R and 6125R

CAPACITIES (Approximate):

Fuel Tank:

Standard	220 L (58 gal)
Optional	265 L (70 gal)

Cooling System:

Cool-Gard™ II

Engine cooling and cab heating	28.2 L (7.5 gal)
--------------------------------------	------------------

Crankcase:

Plus-50™ II

.....	16 L (4.2 gal)
-------	----------------

Transmission/Hydraulics:

Hy-Gard™

PowrQuad™ PLUS transmission	53 L (14 gal)
AutoQuad™ PLUS transmission	53 L (14 gal)
IVT™ transmission	60 L (15.9 gal)
Extra with creeper.....	1 L (0.3 gal)
Extra with additional oil reservoir.....	17 L (4.5 gal)
Front PTO.....	2.6 L (0.69 gal)

Front-wheel drive:

Hy-Gard™

Axle housing.....	8.2 L (2.2 gal)
Final drives (without brake)	1.7 L (0.4 gal)
Final drives (with brake)	2.6 L (0.7 gal)

Air-conditioning system:

R134a refrigerant

.....	1225 - 1275 gr (2.70 - 2.81 lb)
-------	------------------------------------

Oil volume (PAG oil)

.....	220 ml (7.44 fl oz)
-------	---------------------

[Return to Filter Overview](#)

